

HONDA

INSTALLATION INSTRUCTIONS

Accessory

BACKREST BRACKET
P/N 08R71-MJF-A00ZP

Application

CTX700N/ND (Page 1)
CTX700/D (Page 2)

Publication No.

MII 14476

Issue Date

Revised August 2014

PARTS LIST

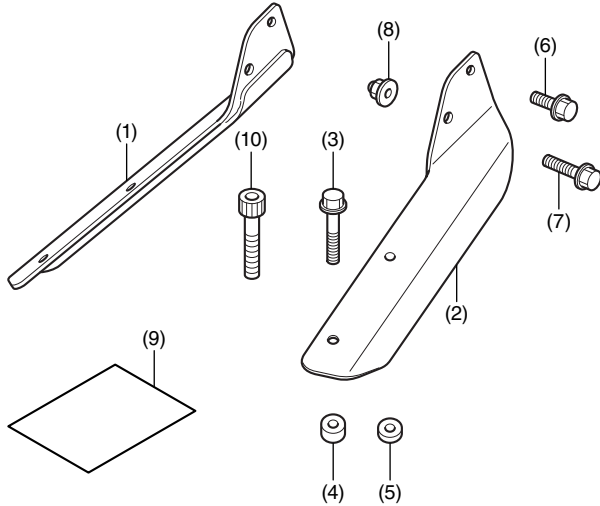

No.	Description	Qty
(1)	Right backrest stay	1
(2)	Left backrest stay	1
(3)	8 mm flange bolt (long)	4
(4)	Collar (thick)	2
(5)	Collar (thin)	2
(6)	8 mm flange bolt (short)	4
(7)	8 mm flange bolt (medium)	4
(8)	8 mm flange cap nut	2
(9)	Installation Instruction URL	1
(10)	8 mm socket bolt (Not used.)	4

INNER SUPPORT (CTX700N/ND Only)

Sold separately

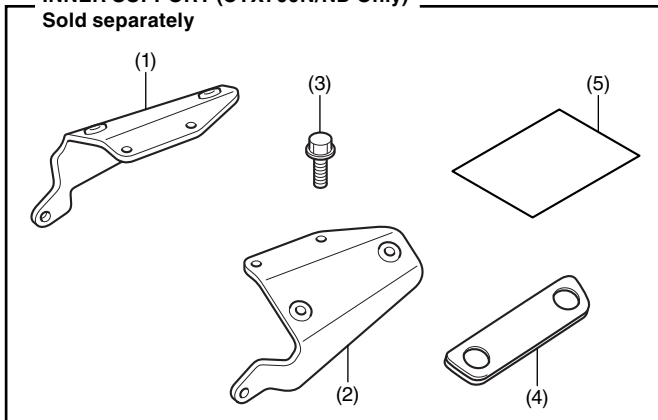

No.	Description	Qty
(1)	Right inner support stay	1
(2)	Left inner support stay	1
(3)	8 mm flange bolt	6
(4)	Cushion	2
(5)	Installation Instruction URL	1

TOOLS REQUIRED

- Socket (12 mm)
- Ratchet
- Box-end wrench (12 mm)
- Torque wrench

TORQUE CHART

Tighten all screws, bolts, and nuts to their specified torque values. Refer to the Service Manual for the torque values of the removed parts.

Item	N-m	kgf-m	lbf-ft
8 mm flange bolt and cap nut	27	2.8	20
8 mm socket bolt	22	2.2	16

INSTALLATION (CTX700N/ND)

NOTE:

- Take care not to damage the painted surfaces of the motorcycle.
 - Illustrations show CTX700N type, other type is similar.**
- Refer to the Installation Instructions for the separately sold inner support, install the inner support to the motorcycle.
 - Loosely install the backrest bracket as shown.
 - Repeat on the right side.**

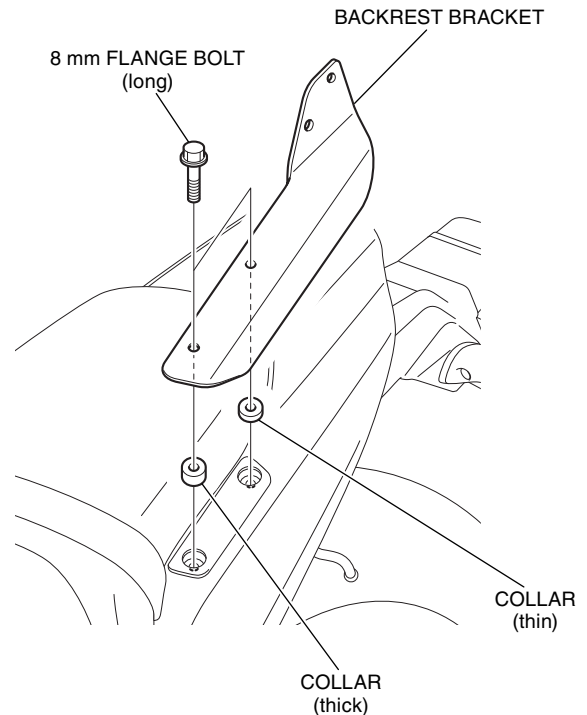

INSTALLATION (CTX700/D)

NOTE:

- Take care not to damage the painted surfaces of the motorcycle.
1. Refer to the Service Manual for the motorcycle, remove the rear grips.
 - **Repeat on the right side.**

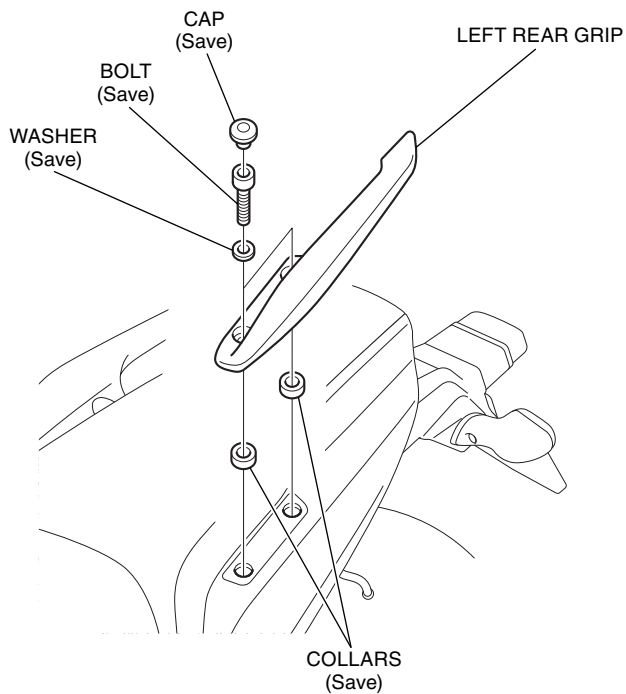

2. Loosely install the backrest bracket as shown.
 - **Repeat on the right side.**

