

Honda Dealer: Please give a copy of these instructions to your customer.

PARTS LIST

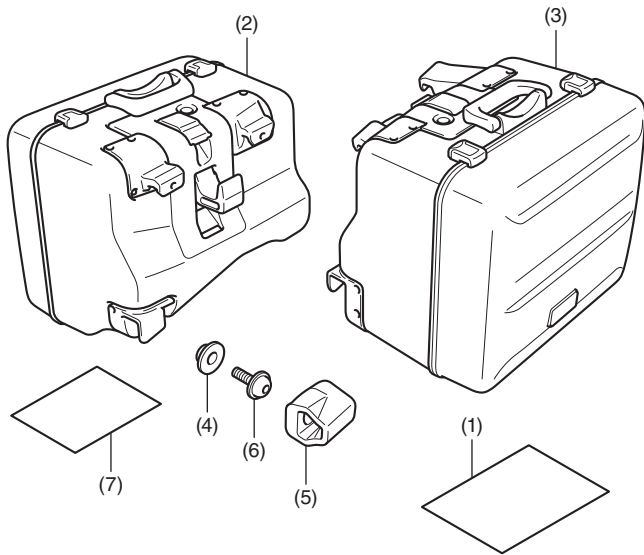

No.	Description	Qty
(1)	Installation Instruction URL	1
(2)	Right pannier	1
(3)	Left pannier	1
(4)	Collar	2
(5)	Rubber cushion	2
(6)	5 mm socket bolt	2
(7)	Label*	2

*: (For USA) **Not used.**
 (For CANADA) Apply the label onto the attached label.

MAXIMUM LOADING CAPACITY

- The weight of the cargo must not exceed the following maximum loading capacity:

Maximum Loading Capacity	
Right pannier	13.2 lb (6.0 kg)
Left pannier	13.2 lb (6.0 kg)

1 KEY INNER CYLINDER (Wave key type)

Sold separately

- Do not use the slots.

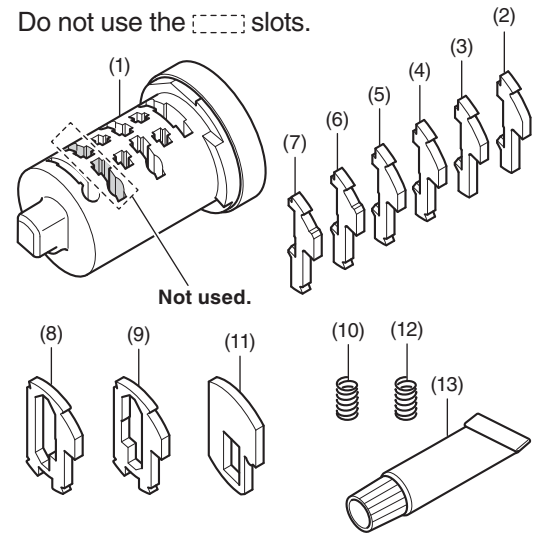

No.	Description	Qty
(1)	Inner cylinder	1
(2)	No.1 tumbler	6
(3)	No.2 tumbler	6
(4)	No.3 tumbler	6
(5)	No.4 tumbler	6
(6)	No.5 tumbler	6
(7)	No.6 tumbler	6
(8)	Sub-lock tumbler A	1
(9)	Sub-lock tumbler B	1
(10)	Spring (Silver)	13
(11)	Stopper tumbler	2
(12)	Stopper spring (Black)	2
(13)	Grease	1

TOOLS REQUIRED

Hex wrench (3 mm)

Torque wrench

TORQUE CHART

Tighten all screws, bolts, and nuts to their specified torque values. Refer to the Service Manual for the torque values of the removed parts.

Item	N·m	kgf·m	lbf·ft
5 mm socket bolt	5.2	0.5	3.8

< Notes regarding the key cylinder >

- This product is used to assemble a key cylinder matching the motorcycle key by combining six types of tumblers.
- When this key cylinder is installed in a box or similar equipment, the installed equipment can be operated with the motorcycle key.

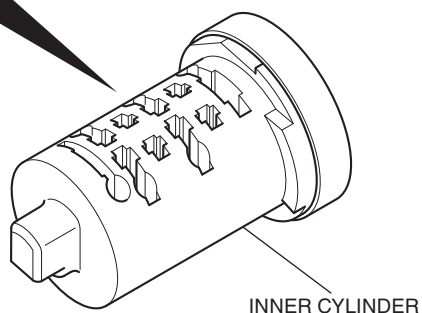
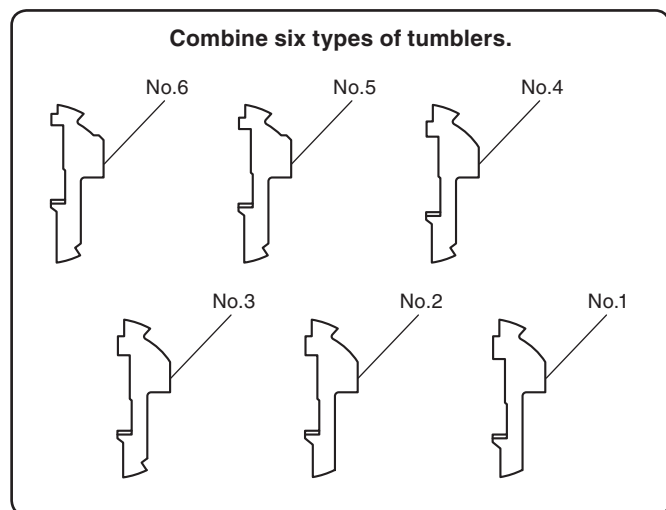

INSTALLATION

▲ CAUTION

- To prevent burns, allow the engine, exhaust system, radiator, etc., to cool before installing and removing the accessory.

1. Install the rubber cushion as shown.

<Left side>

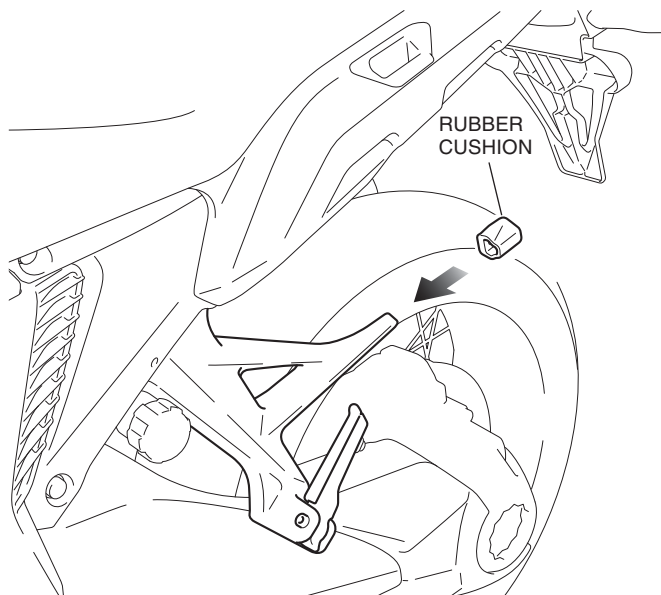

2. Insert the socket bolt and collar as shown.

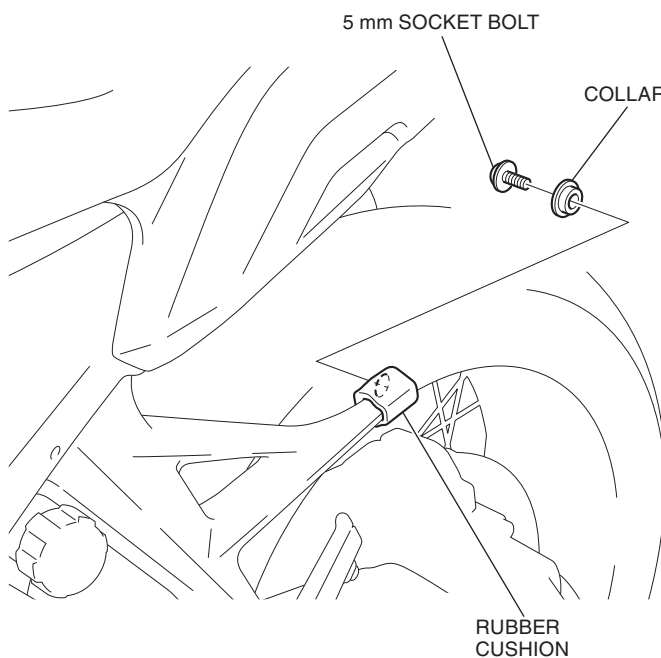

3. Install the right rubber cushion in the same manner as the left side.

- As two key cylinders are required, make two cylinders using following procedures.

- The two sub-lock tumbler types shown are provided.
 - The  part has a different slot for each of the two sub-lock tumbler types.
 - As the tumblers are small, keep them in the bag until they are used.

SUB-LOCK TUMBLER A

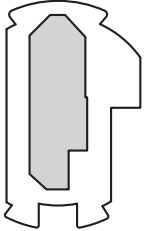

SUB-LOCK TUMBLER B



The stopper tumbler will be used later.



- The six tumbler types shown are provided.
 - The  part has a different width for each of the six tumbler types.
 - As the tumblers are small, keep them in the bag until they are used.

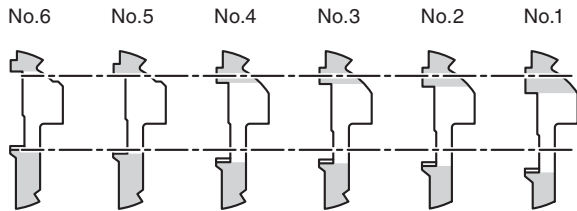

- Install the tumblers and springs (silver) as shown.
 - First install four No.1 tumblers.
 - Note the installed tumbler to below chart.

Insert tumblers and springs at the shaded positions.

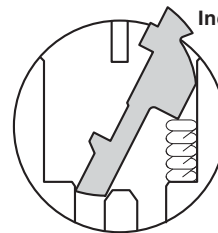
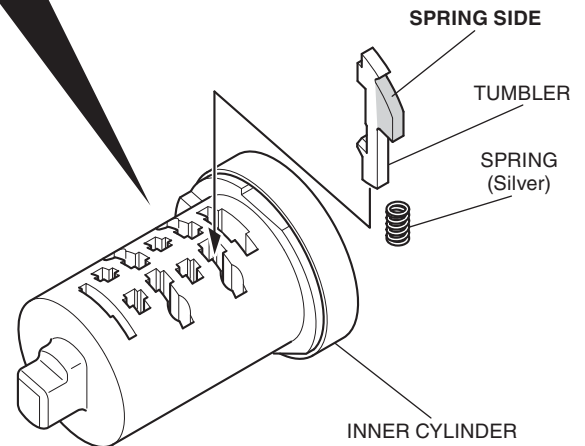
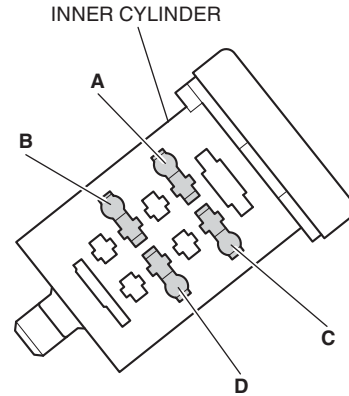

Incorrect.

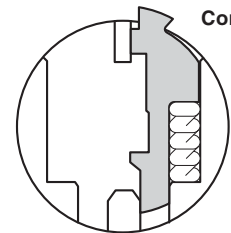

Correct.

	Position A	Position B	Position C	Position D
No.1 tumbler				
No.2 tumbler				
No.3 tumbler				
No.4 tumbler				
No.5 tumbler				
No.6 tumbler				

7. Insert the key as shown.
- **Lightly press down on the tumblers from above, then insert the key.**

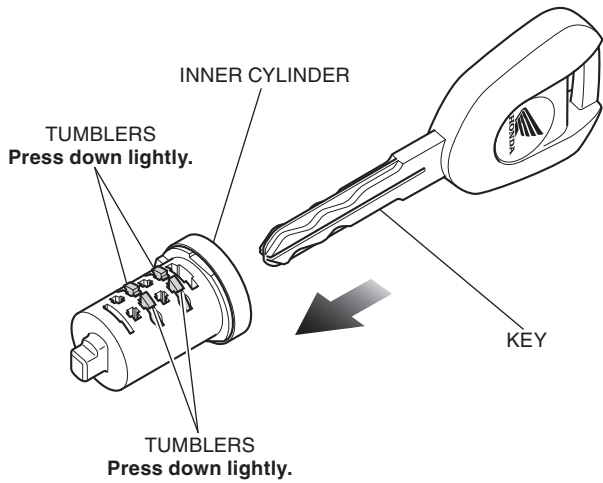

8. Confirm that some tumblers are projecting. Mark the positions of the projected tumblers.
- **The positions where tumblers project and the projecting height differ according to the key.**

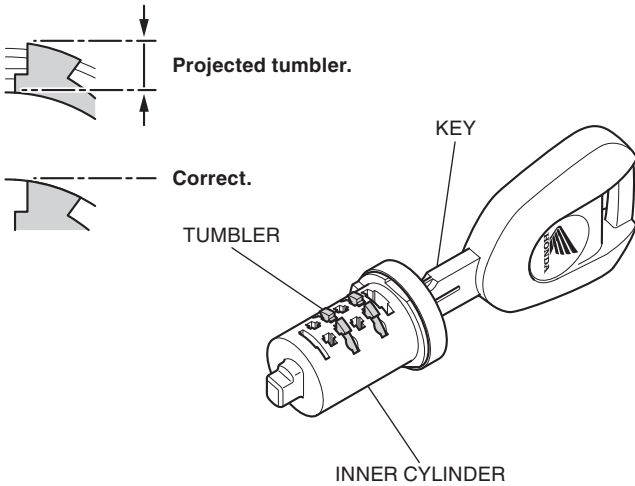

9. Press down lightly on the tumbler, pull the key out.
- **The tumbler spring may jump out when the tumbler is not pressed down lightly.**

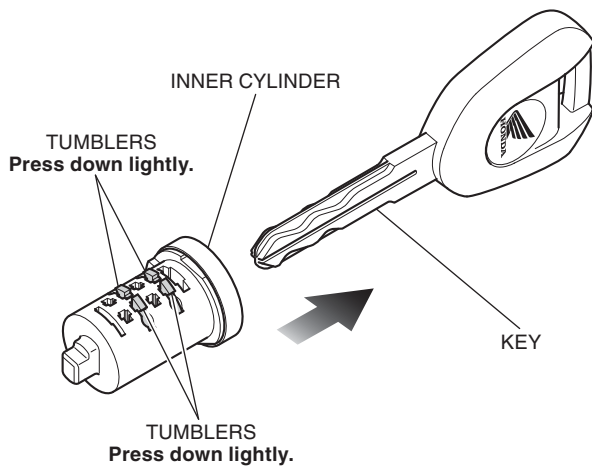

10. Pull out the projecting tumbler(s).
- **Leave the spring(s) installed.**

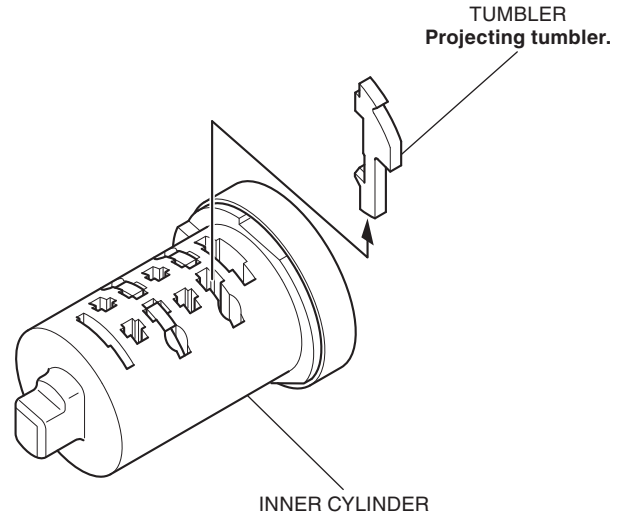

11. Insert a different tumbler(s) at the marked positions.
- **Use a tumbler of the next number up.**

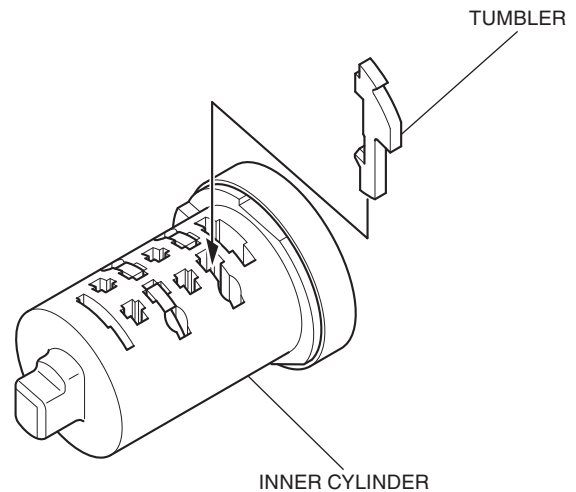

12. Repeat steps 7 to 11, inserting different tumblers at the marked positions until no tumblers are projected.
- **Lightly press down on the tumblers from above, then insert the key.**

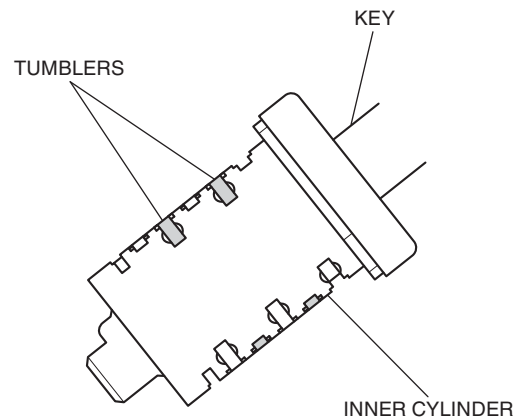

13. Install the tumblers and springs (silver) to the reverse side inner cylinder as shown.

- **First install two No.1 tumblers.**

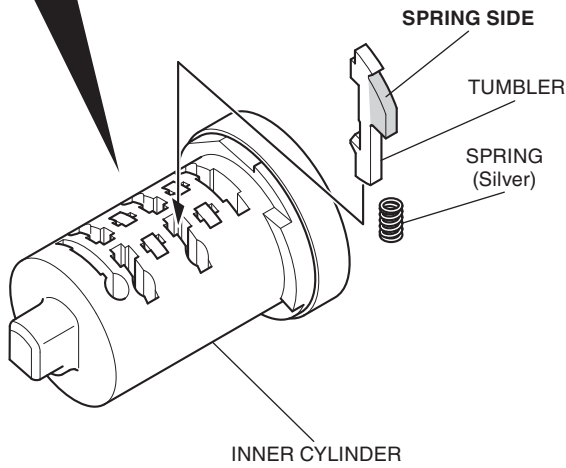
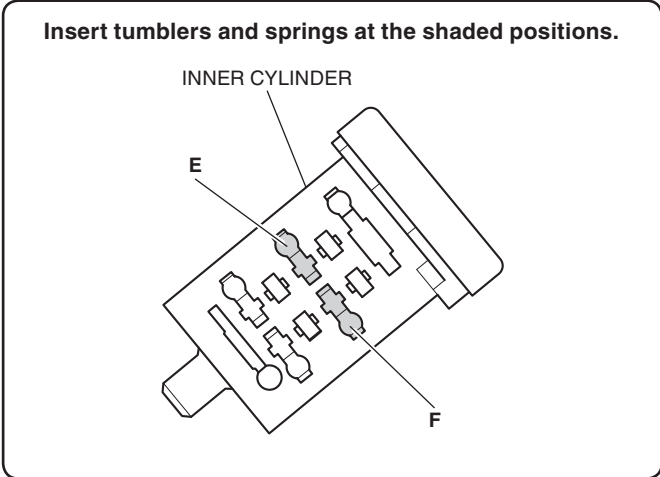

- **Note the installed tumbler to below chart.**

	Position E	Position F
No.1 tumbler		
No.2 tumbler		
No.3 tumbler		
No.4 tumbler		
No.5 tumbler		
No.6 tumbler		

14. Use steps 7 through 11 to assemble the reverse side inner cylinder in the same manner.

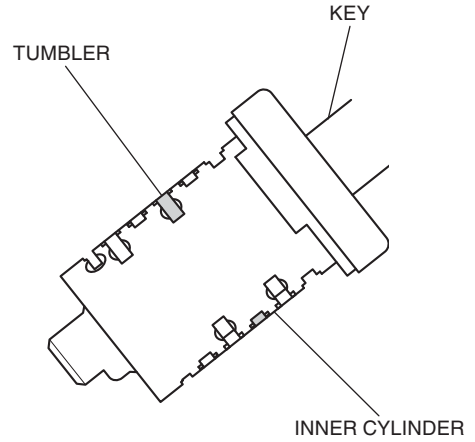

15. Install the sub-lock tumbler as shown.

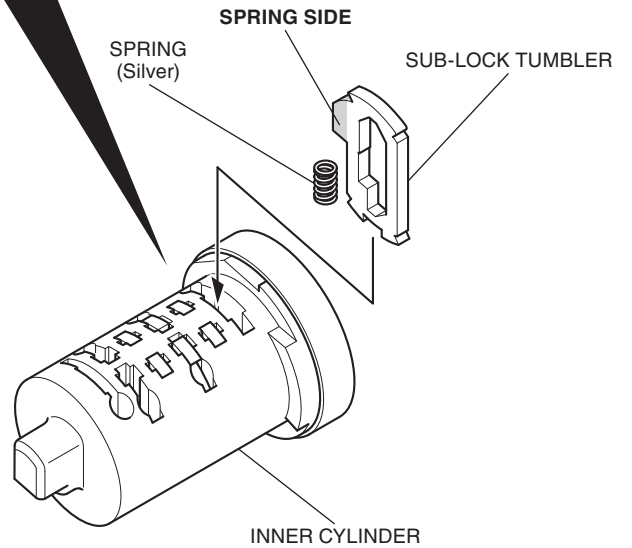
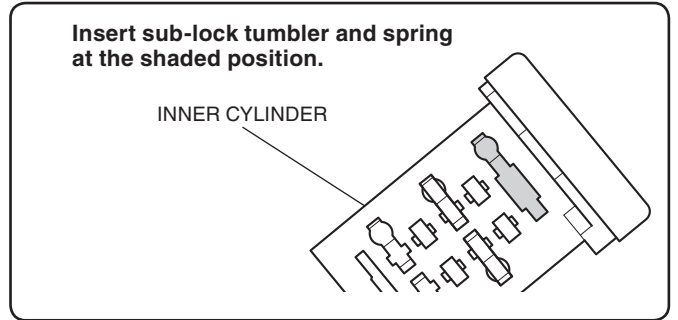

- **Note the installed tumbler to below chart.**

Sub-lock tumbler A	
Sub-lock tumbler B	

16. Confirm that sub-lock tumbler is not projecting.
- **If the tumbler is projected, change the another sub-lock tumbler and recheck.**

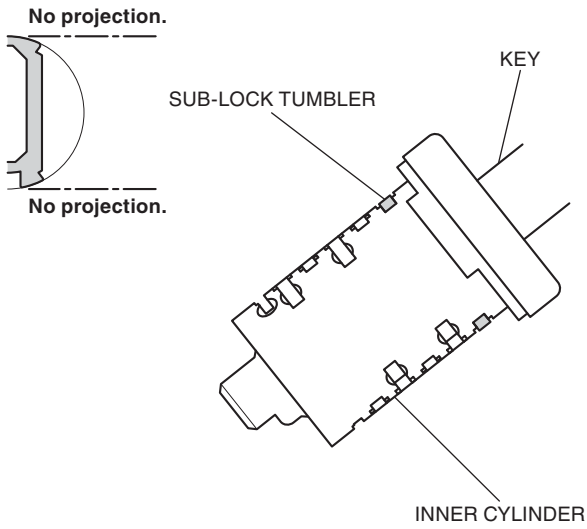

17. Insert the assembled inner cylinder into the key cylinder as shown.
- **Confirm the inner cylinder turns clockwise smoothly.**

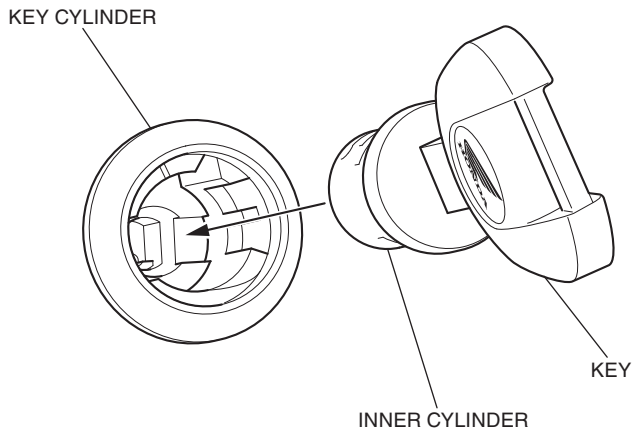

18. Pull out the inner cylinder.
19. Press down lightly on the tumblers and pull out the key.

20. Install the stopper tumbler and stopper spring (black) as shown.

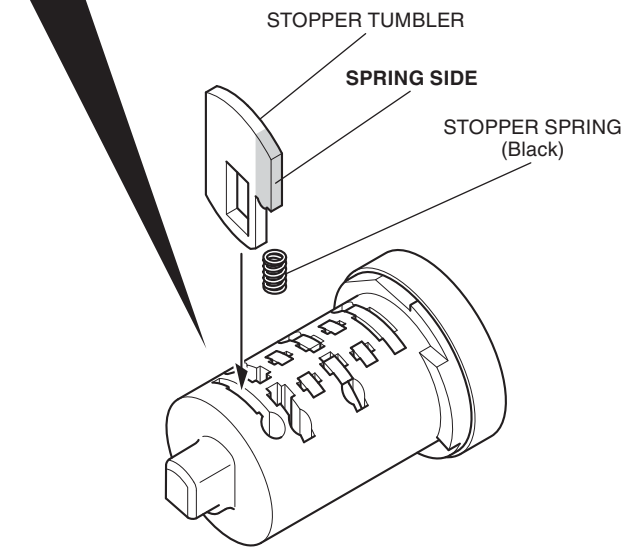
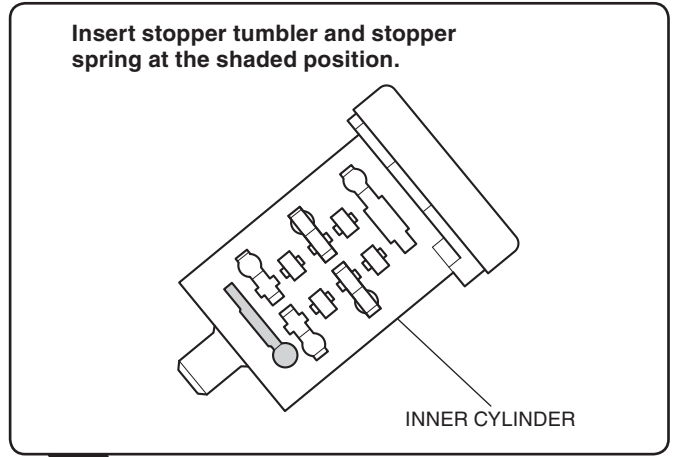

21. Insert the key as shown.
- **Lightly press down on the tumblers from above, then insert the key.**
 - **Confirm that the stopper tumbler jumps out.**

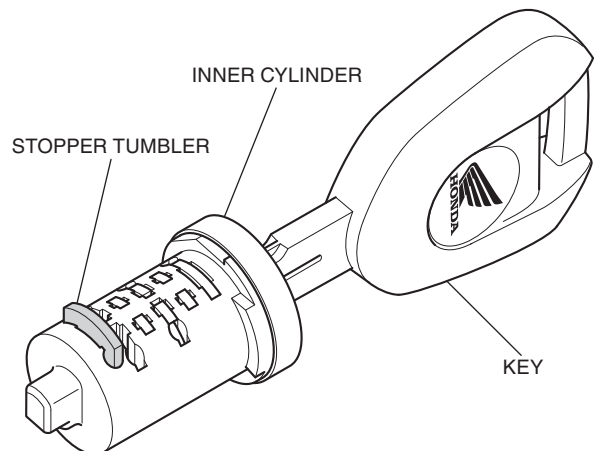

22. Apply grease to the shaded areas as shown.
- Apply to the tumbler and to the outer circumference of the inner cylinder.
 - Only use the supplied grease.

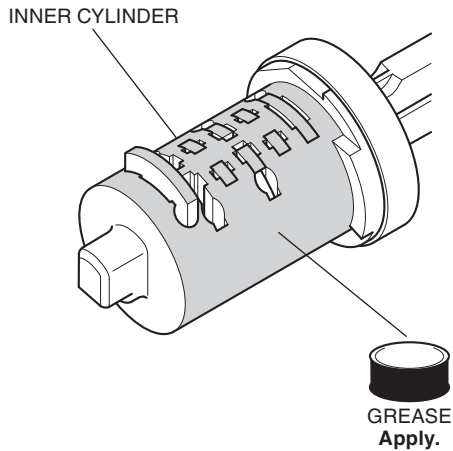

23. Install the inner cylinder by sliding the stopper tumbler along the slide guide while rotating it.
- If the inner cylinder cannot be inserted, again confirm that no tumblers other than the stopper tumbler have jumped out.

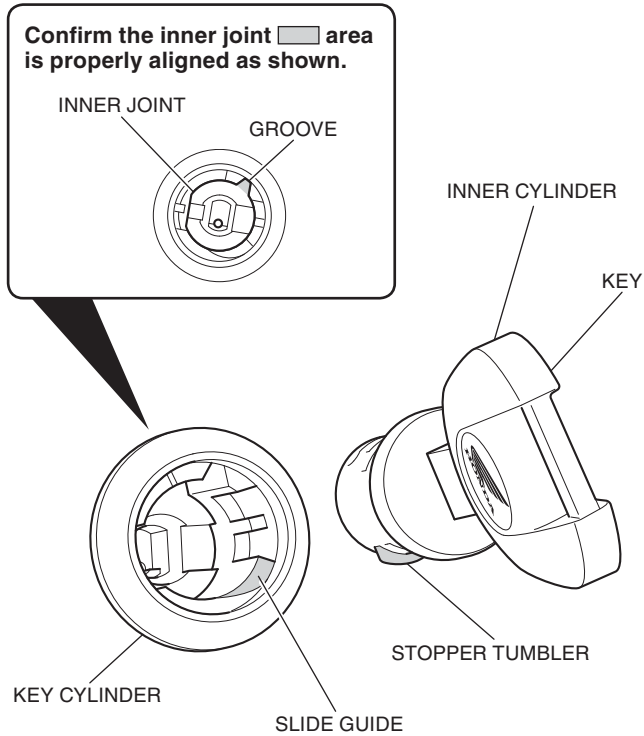

Push in the inner cylinder while turning it clockwise until the stopper tumbler is locked.

24. Draw out the key and check that the inner cylinder does not come out.

FOR USE OF THE PANNIERS

▲ CAUTION

- To prevent burns, allow the engine, exhaust system, radiator, etc., to cool before installing and removing the accessory.

How to Install the Panniers

1. Release the lock by turning the key clockwise.

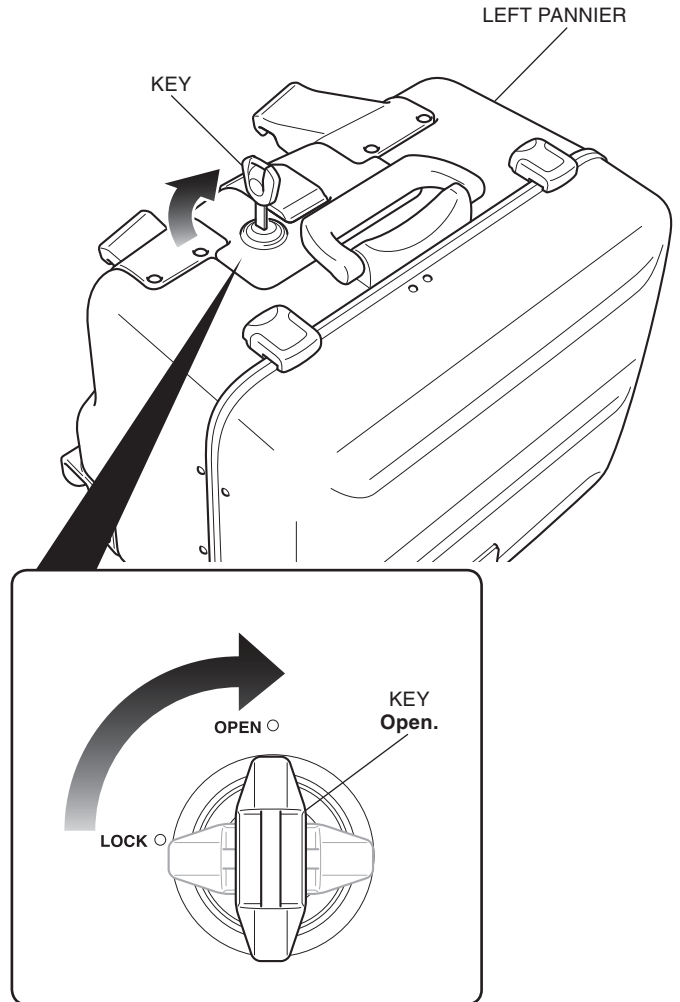

2. Insert the left pannier as shown.
- **First engage at the step rubber cushion and then install at the two holes.**

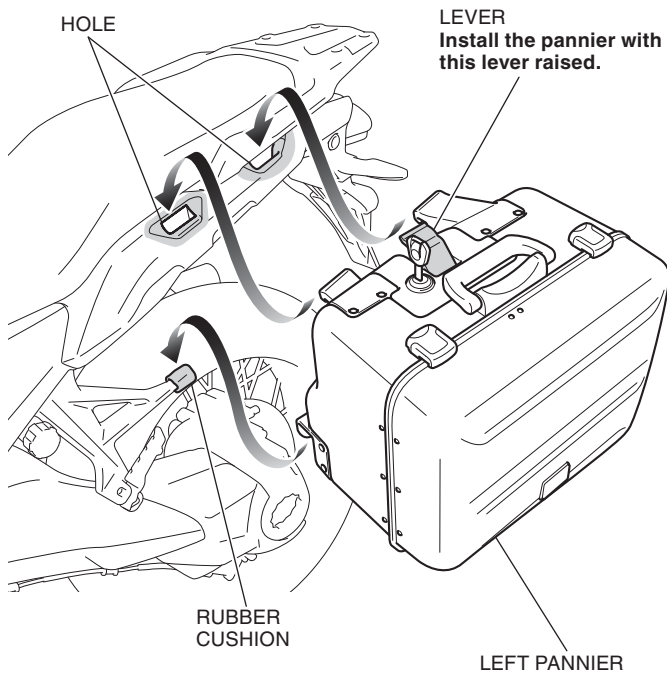

3. Lower the lever as shown.

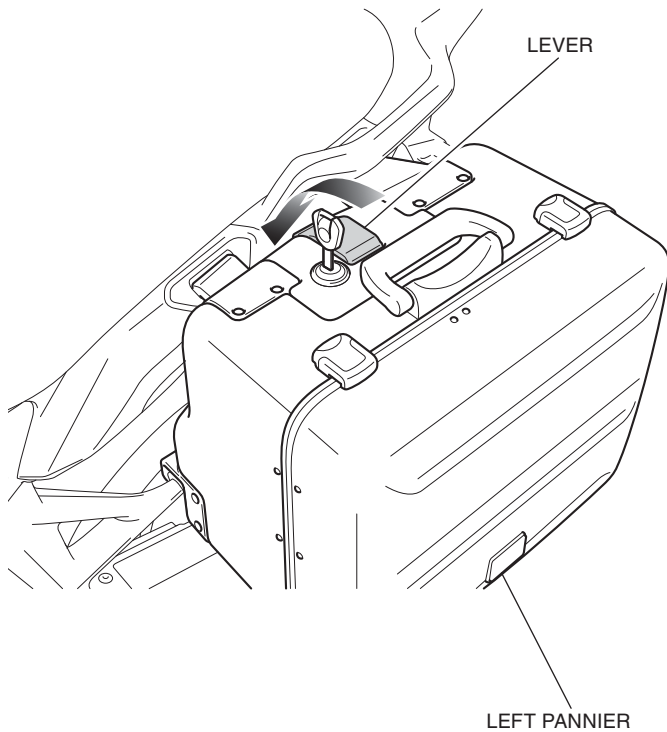

4. Lock the pannier by turning the key in the direction shown.

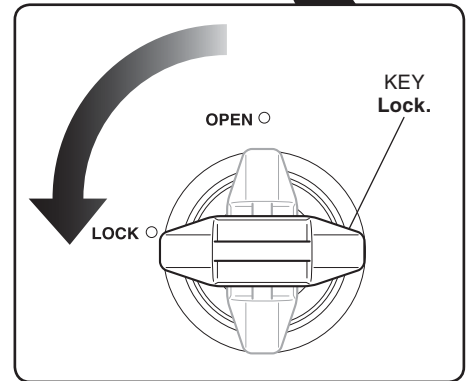
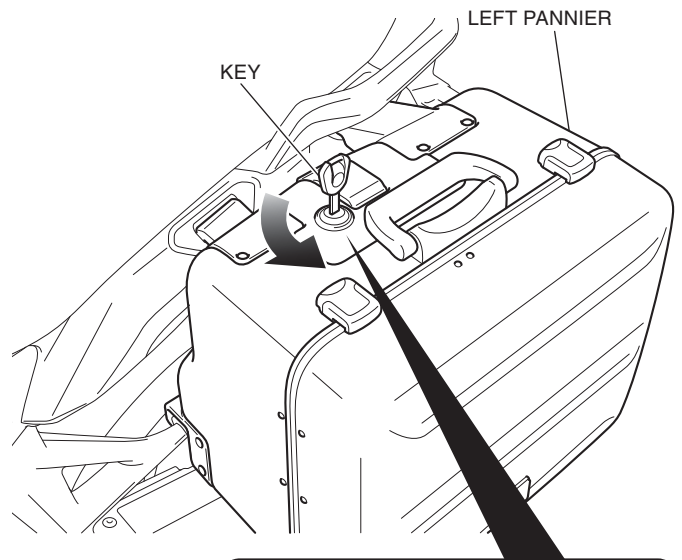

5. Remove the key. Be sure that the lever cannot be released and the pannier is installed securely.
- **The pannier can come off during riding unless it is mounted securely.**

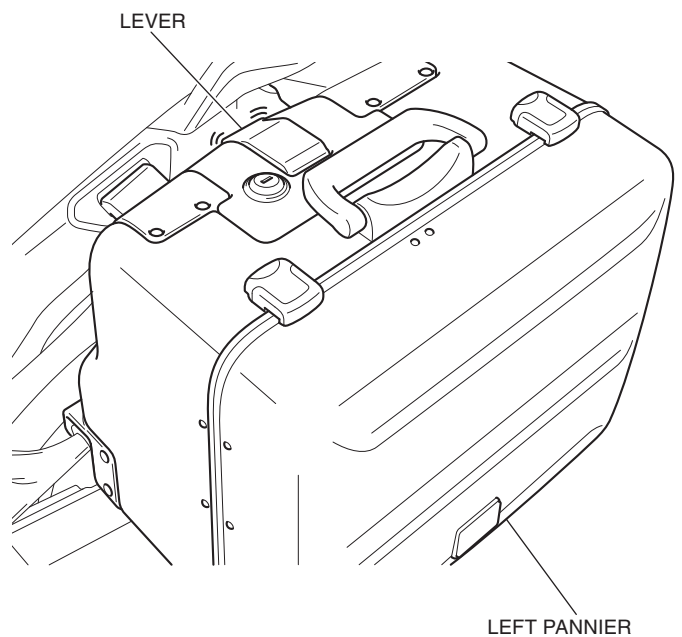

6. Install the right pannier in the same manner as left side.

How to Open the Panniers

1. Install the key and release the lock by turning the key in the direction shown.

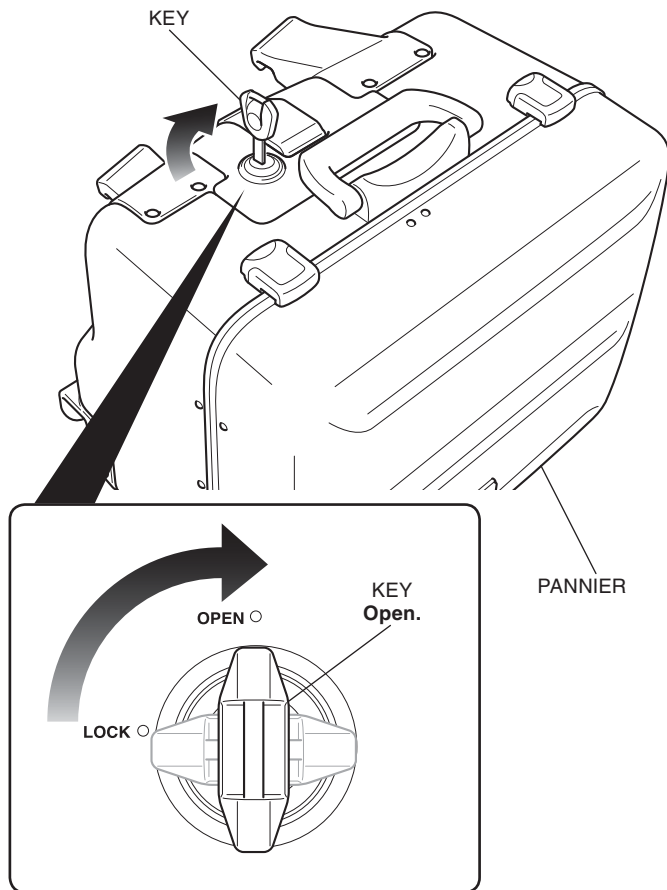

2. Open the latch as shown.

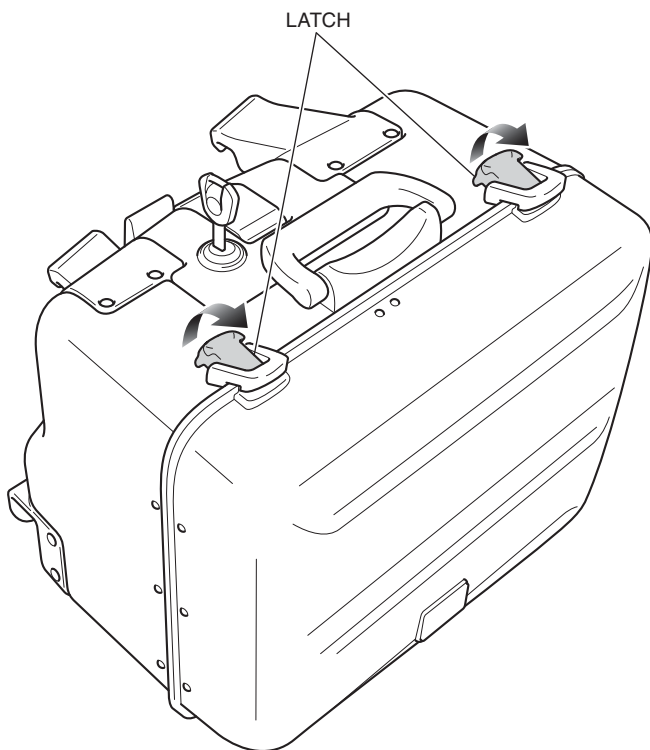

3. Open the lid as shown.

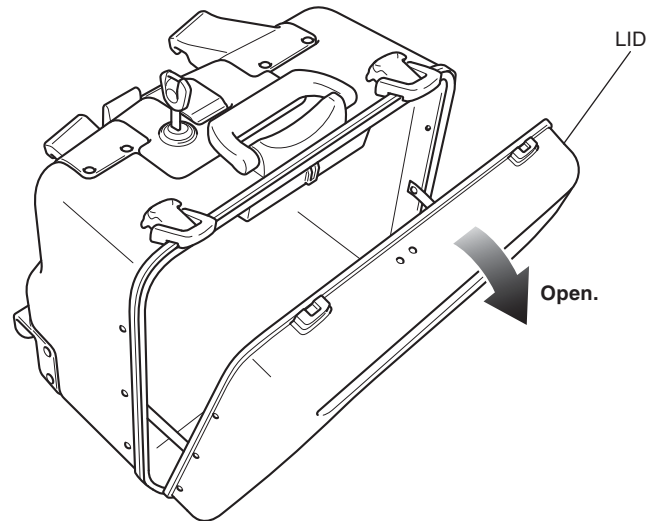

How to Close the Panniers

NOTE:

- Be sure that the lid is closed securely before riding.
1. Close and lock the panner in reverse order of opening.
 - **Be careful not to have the stopper belt pinched when the lid is closed.**

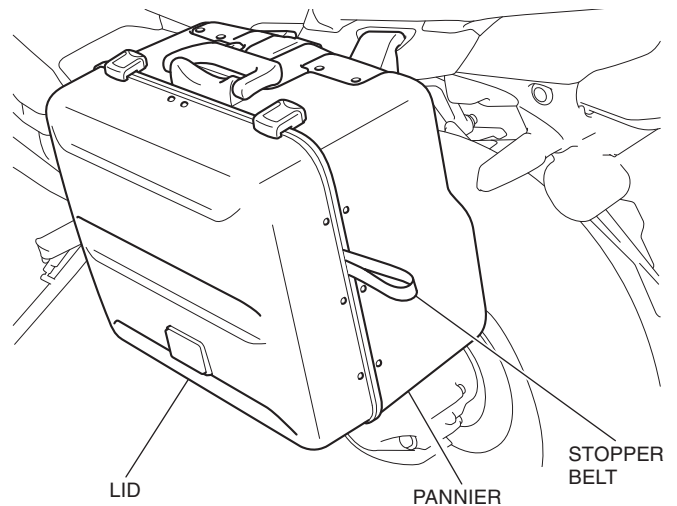

How to Remove the Panniers

1. Remove the panniers in the reverse order of installation.