

HONDA

INSTALLATION INSTRUCTIONS

Accessory
HANDLEBAR RISER KIT
 P/N 08R70-MJM-D10

Application
VFR800F/D

Publication No.
MII 14983
 Issue Date
June 2014

PARTS LIST

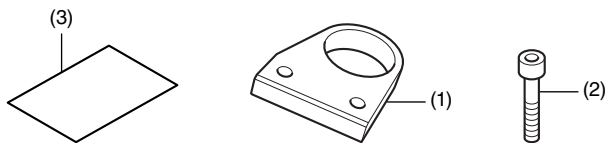

| No. | Description | Qty |
|-----|------------------------------|-----|
| (1) | Handlebar riser | 2 |
| (2) | 8 mm socket bolt | 4 |
| (3) | Installation Instruction URL | 1 |

TOOLS REQUIRED

Hex wrench (6 mm)
 Torque wrench

TORQUE CHART

Tighten all screws, bolts, and nuts to their specified torque values. Refer to the Service Manual for the torque values of the removed parts.

| Item | N·m | kgf·m | lbf·ft |
|------------------|-----|-------|--------|
| 8 mm socket bolt | 22 | 2.2 | 16 |

Customer Information: The information in these Accessory Installation Instructions are intended for use only by skilled technicians who have the proper tools, equipment, and training to correctly and safely add equipment to the motorcycle.

INSTALLATION

1. Remove the indicated parts.

<Right side>

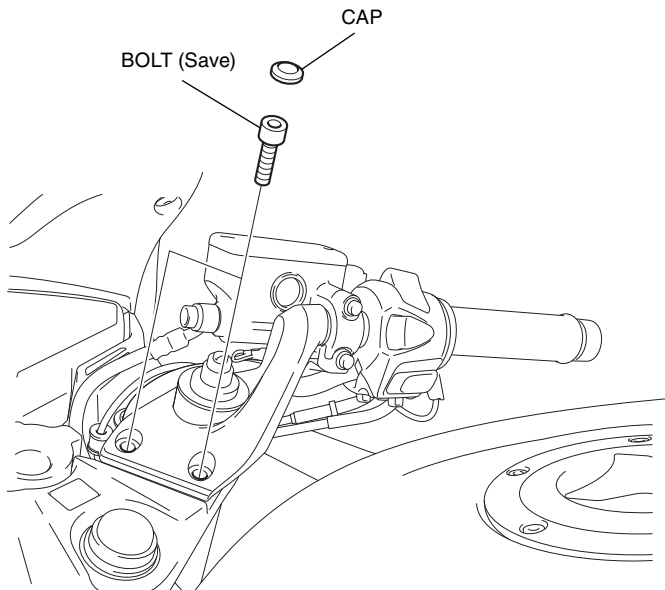

2. Pull out the right handlebar assembly from the front fork as shown.

- Be sure to keep the master cylinder horizontal after the removal.

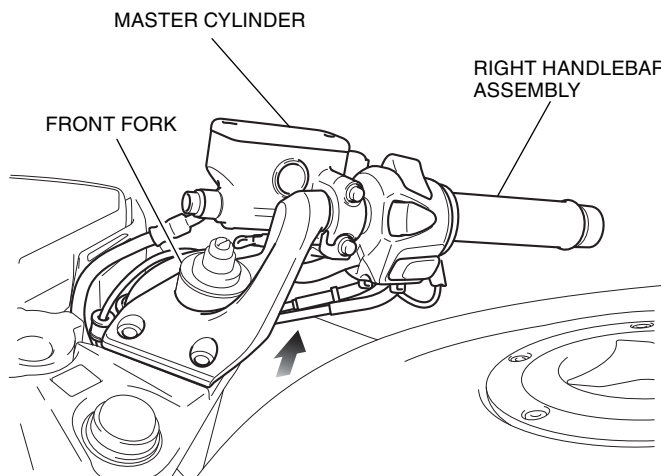

3. Install the handlebar riser as shown.

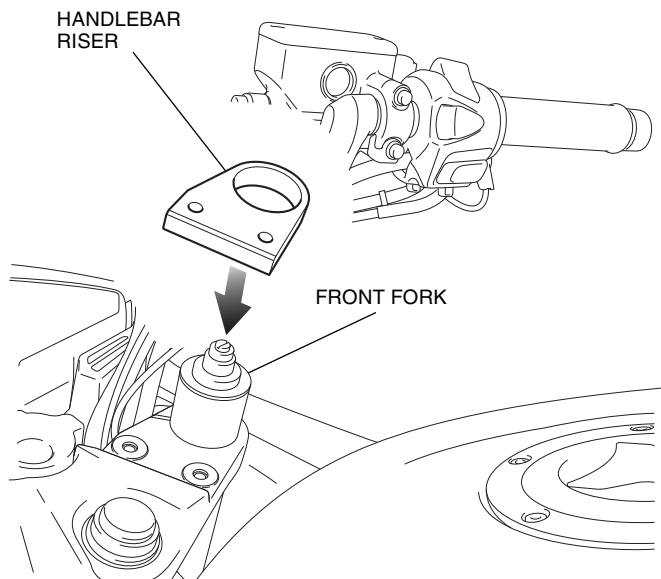

4. Install the right handlebar assembly in the reverse order of removal.

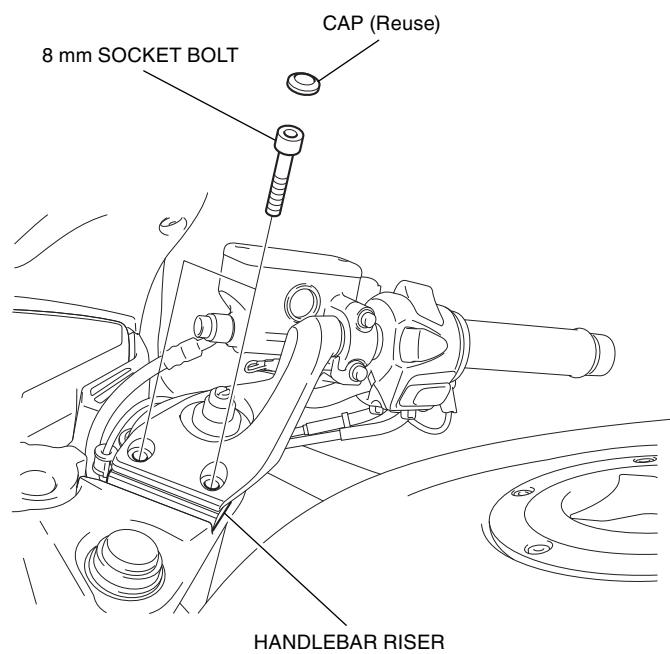

5. Repeat Steps 1 through 4 on the left side.