



# INSTALLATION INSTRUCTIONS

Accessory
<b>TANK BAG</b> P/N 08L71-MKJ-D00

Application
<b>CB1000RA</b>

Publication No.
<b>MII 16775</b>
Issue Date
<b>August 2018</b>

**Honda Dealer: Please give a copy of these instructions to your customer.**

## PARTS LIST

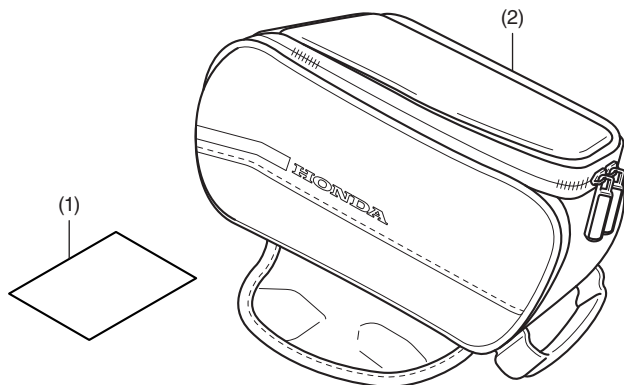

No.	Description	Qty
(1)	Installation Instruction URL	1
(2)	Tank bag	1

### TANK BAG ATTACHMENT

Sold separately

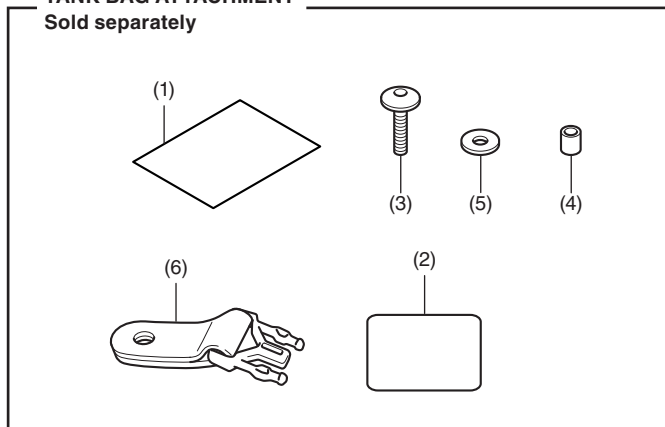

No.	Description	Qty
(1)	Installation Instruction URL	1
(2)	Protection film	2
(3)	6 x 20 mm screw	2
(4)	Collar	2
(5)	Washer	2
(6)	Tank bag strap	2

## TOOLS AND SUPPLIES REQUIRED

- Hex wrench (5 mm)
- Isopropyl alcohol
- Shop towel
- Torque wrench

## TORQUE CHART

Tighten all screws, bolts, and nuts to their specified torque values. Refer to the Service Manual for the torque values of the removed parts.

Item	N·m	kgf·m	lbf·ft
6 mm screw	10	1.0	7

## MAXIMUM LOADING CAPACITY

- The weight of the cargo must not exceed the following maximum loading capacity:

Maximum Loading Capacity	
Tank bag	1.0 kg (2.2 lb)

## INSTALLATION

### ▲ CAUTION

- To prevent burns, allow the engine, exhaust system, radiator, etc., to cool before installing the accessory.

### NOTE:

- Heat the bonding surfaces with a hair dryer if the ambient air temperature is below 70°F (21°C).
- The adhesive reaches full strength in 72 hours. Wait at least 24 hours before riding your motorcycle.
- Before installation, remove all dust, sand, etc. from fuel tank and tank bag, as otherwise the fuel tank may be damaged.

- Remove the screws as shown.

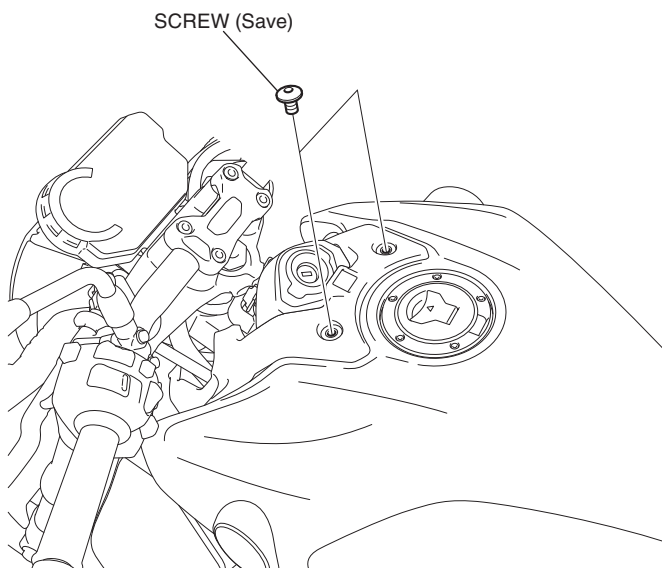

2. Clean the surface of the area shown using isopropyl alcohol.

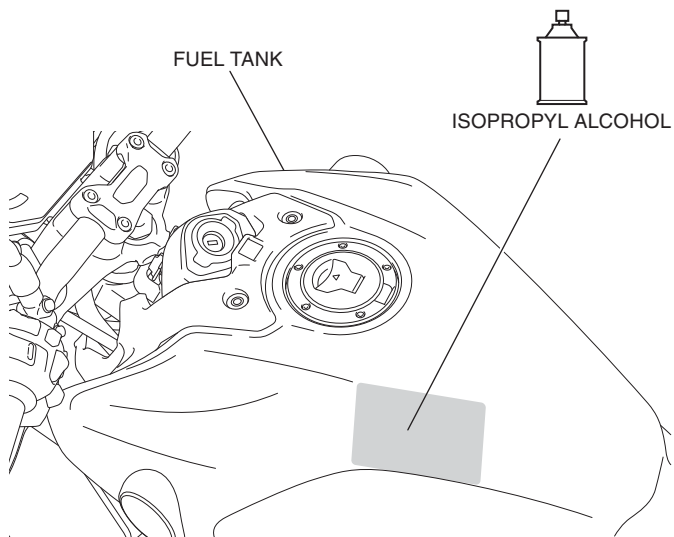

3. Attach the protection film to the fuel tank as shown.

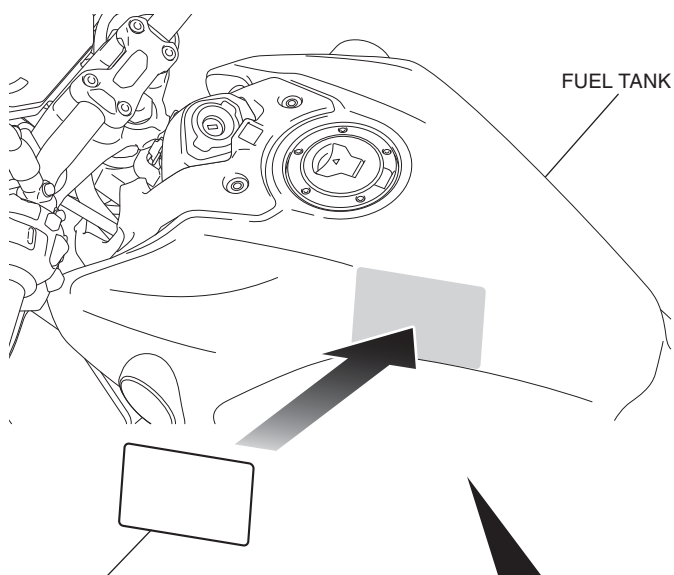

**PROTECTION FILM**  
Remove the adhesive backing before attaching.

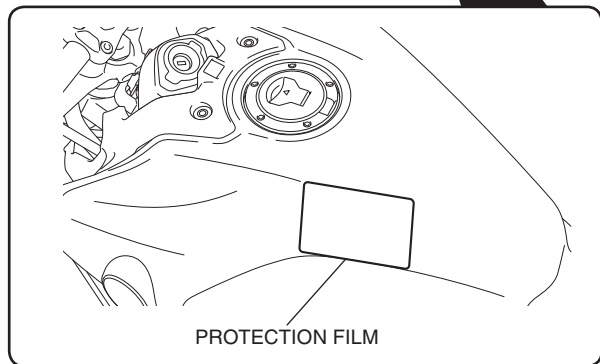

4. Attach the right side in the same manner as the left side.

5. Install the tank bag straps as shown.

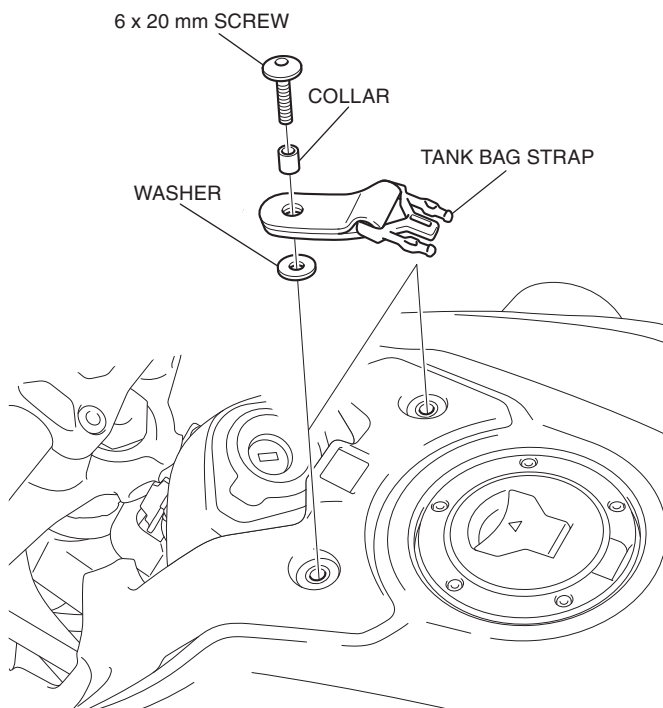

6. Install the tank bag on the fuel tank as shown.

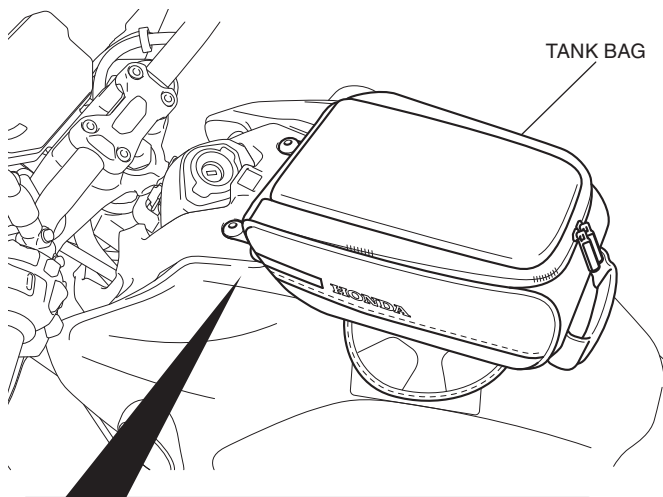

**Lock the buckles as shown.**

