



INSTALLATION INSTRUCTIONS

Accessory REAR FRAME SKID PLATE P/N 08P51-HP7-100B	Application TRX420FA/FPA	Publications No. MII 13151
		Issue Date February 2010

Honda Dealer: Please give a copy of these instructions to your customer.

PARTS LIST

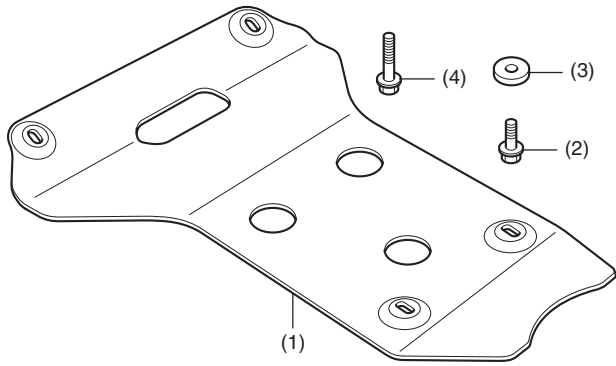

No.	Description	Qty
(1)	Rear frame skid plate	1
(2)	6 mm flange bolt (short)	2
(3)	Collar	8
(4)	6 mm flange bolt (long)	2

TOOLS REQUIRED

- Socket (10 mm)
- Ratchet
- Torque wrench
- Thread lock

TORQUE CHART

Tighten all screws, bolts, and nuts to their specified torque values. Refer to the Service Manual for the torque values of the removed parts.

Item	N-m	kgf-m	lbf-ft
6 mm flange bolt	12	1.2	9

USE AND CARE INFORMATION

- Check the accessory mounts frequently and retighten if necessary.

SAFETY MESSAGES

As you read these instructions, you will see WARNINGS, CAUTIONS, NOTICES, and NOTES. These safety messages identify the hazard, indicate how to avoid the hazard, and advise of the probable consequence of not avoiding it. Each safety message has a specific purpose:

- WARNINGS** are safety messages that indicate a potentially hazardous situation which, if not avoided, could result in serious injury or death.
- CAUTIONS** are safety messages that indicate a potentially hazardous situation which, if not avoided, could result in minor or moderate injury.
- NOTICES** are messages to avoid vehicle or property damage.
- NOTES** are additional information to help you complete a procedure.

Please work safely!

INSTALLATION

NOTE:

- To prevent burns, allow the engine, exhaust system, radiator, etc., to cool before installing the accessory.

1. Remove the skid plate as shown.

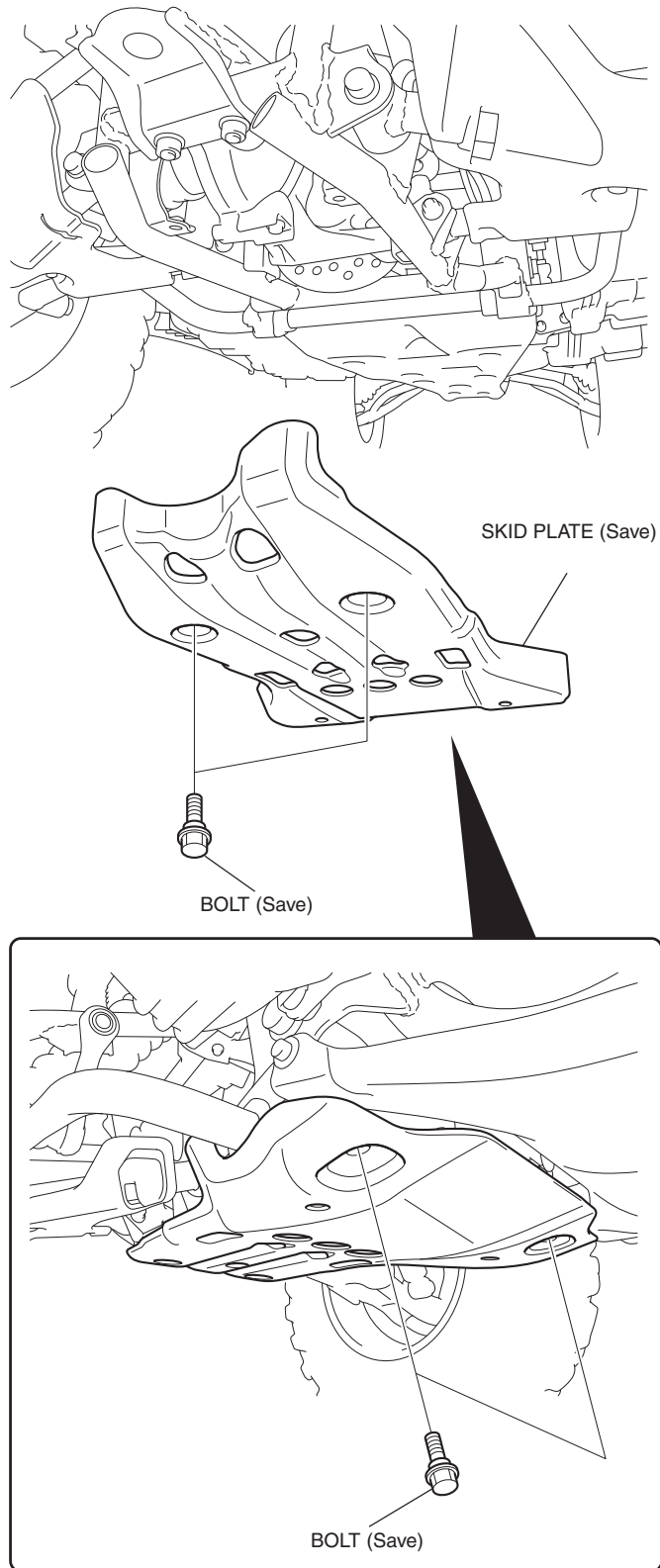

2. Install the rear frame skid plate as shown.

