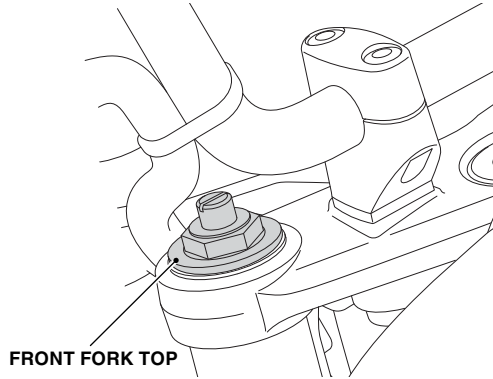
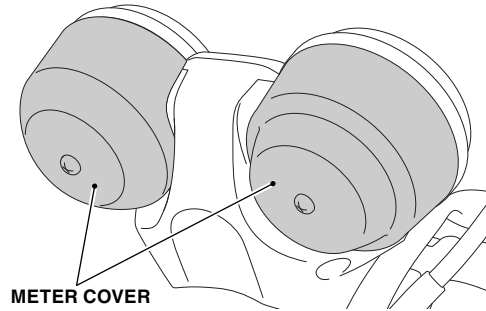
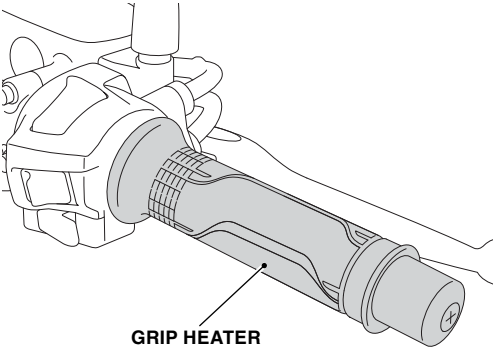

FRONT FORK TOP

- When this accessory becomes dirty, rinse it thoroughly with cool water to remove loose dirt, then wipe with a clean cloth or sponge.
- Do not use a brush to clean this accessory as it may scratch the surface.
- Never use organic solvents such as gasoline, thinner, or benzine to clean this accessory. Also do not use acid or alkaline cleaners to clean this accessory.
- Wipe up spilled brake at once as it may damage the surface.

METER COVER

- When this accessory becomes dirty, rinse it thoroughly with cool water to remove loose dirt, then wipe with a clean cloth or sponge.
- Do not use a brush to clean this accessory as it may scratch the surface.
- Never use organic solvents such as gasoline, thinner, or benzine to clean this accessory. Also do not use acid or alkaline cleaners to clean this accessory.
- Wipe up spilled brake fluid at once as it may damage the plastic surface.

GRIP HEATER

- This accessory replaces the throttle pipe with a combined heated grip/throttle pipe. Therefore, the throttle operation has a different feel after installation.
- Use a 5A fuse for replacement of the fuse of this accessory harness. Do not use any other fuse for replacement.

<RIGHT SIDE>

FUSE

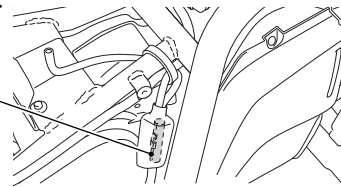
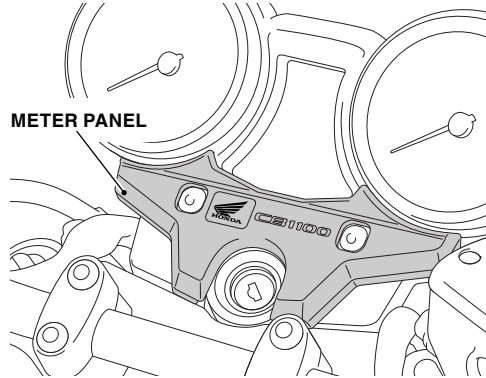
METER PANEL

- When this accessory becomes dirty, rinse it thoroughly with cool water to remove loose dirt, then wipe with a clean cloth or sponge.
- Do not use a brush to clean this accessory as it may scratch the surface.
- Never use organic solvents such as gasoline, thinner, or benzine to clean this accessory. Also do not use acid or alkaline cleaners to clean this accessory.
- Wipe up spilled brake fluid at once as it may damage the plastic surface.

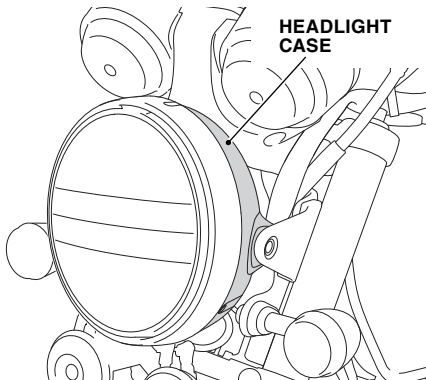
HEADLIGHT CASE

- When this accessory becomes dirty, rinse it thoroughly with cool water to remove loose dirt, then wipe with a clean cloth or sponge.
- Do not use a brush to clean this accessory as it may scratch the surface.
- Never use organic solvents such as gasoline, thinner, or benzine to clean this accessory. Also do not use acid or alkaline cleaners to clean this accessory.
- Wipe up spilled brake fluid at once as it may damage the plastic surface.

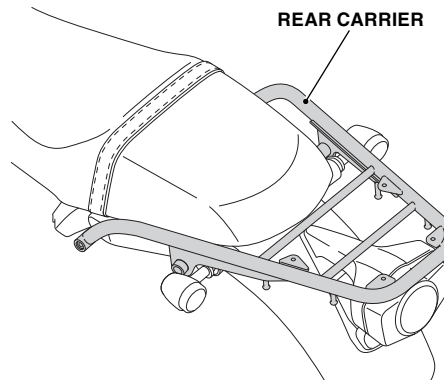
REAR CARRIER

- The weight of the cargo must not exceed the following maximum weight capacity:
17.6 lb (8.0 kg)

SIDE COVER

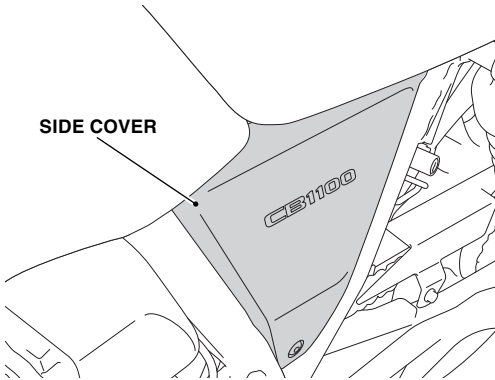

- When this accessory becomes dirty, rinse it thoroughly with cool water to remove loose dirt, then wipe with a clean cloth or sponge.
- Do not use a brush to clean this accessory as it may scratch the surface.
- Never use organic solvents such as gasoline, thinner, or benzene to clean this accessory. Also do not use acid or alkaline cleaners to clean this accessory.
- Wipe up spilled brake or battery fluid at once as it may damage the plastic surface.

TOP BOX

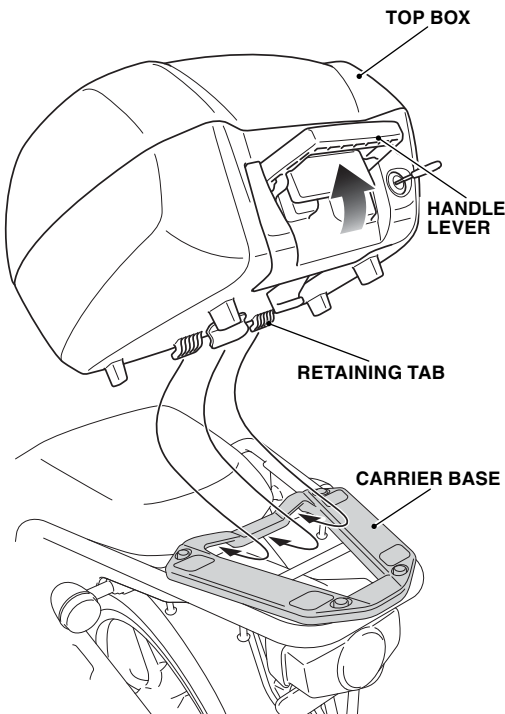

- The weight of the cargo must not exceed the following maximum weight capacity:
6.6 lb (3.0 kg)
- Be sure that the top box is installed securely before riding.
- The top box is not perfectly watertight, and water may enter when washing the motorcycle or when it rains.

HOW TO INSTALL THE TOP BOX

1. Insert the retaining tabs of the top box into the carrier base as shown.
 - Install the top box with the handle lever raised.

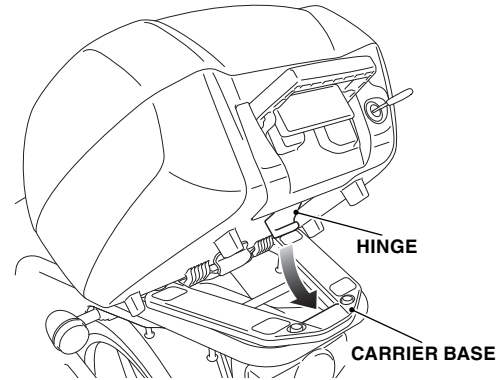

2. Position the hinge of the lock assembly on the carrier base as shown.

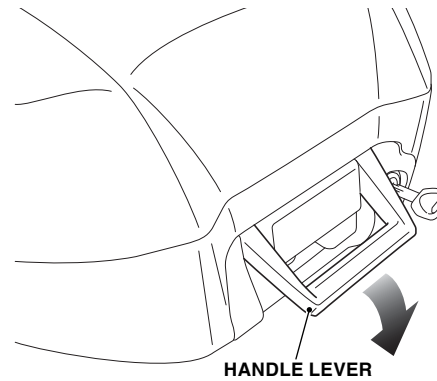

3. Lower the handle lever as shown.

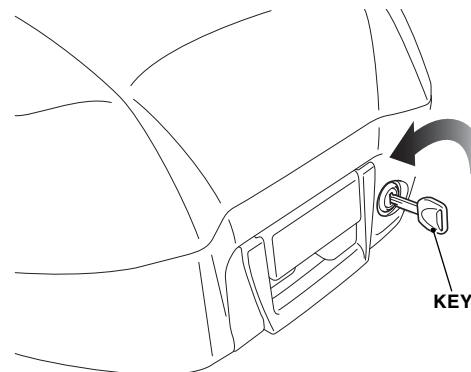

4. Lock the top box by turning the key in the direction shown.

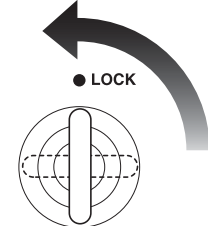

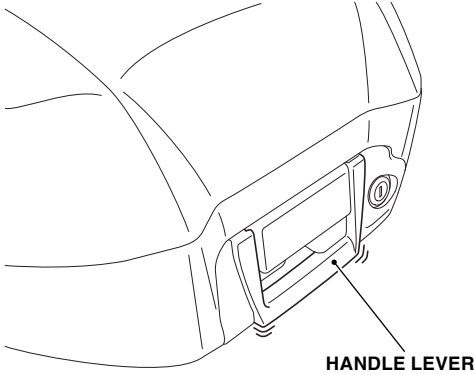

5. Be sure that handle lever cannot be released and the top box is installed securely.
 - The top box may come off while riding unless it is mounted securely.

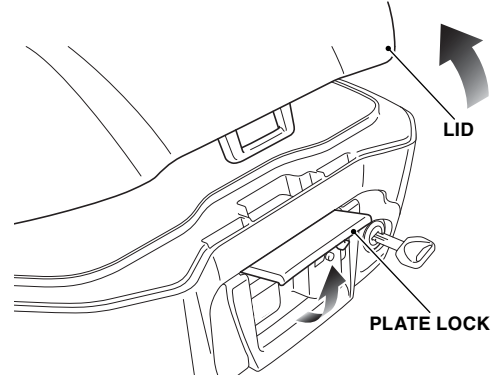

2. Raise the plate lock and open the lid.

HOW TO REMOVE THE TOP BOX

1. Remove the top box in the reverse order of installation.

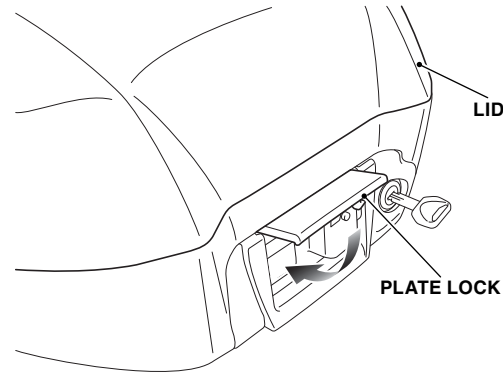

HOW TO CLOSE THE TOP BOX

1. Close the lid and lower the plate lock.

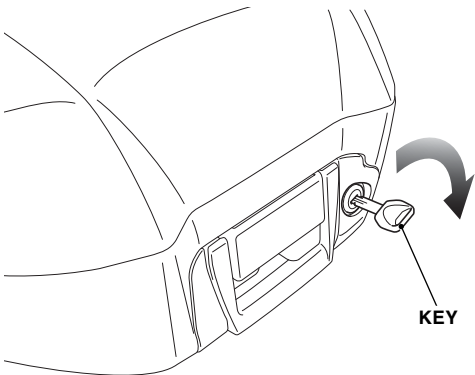

HOW TO OPEN THE TOP BOX

1. Release the lock by turning the key clockwise.

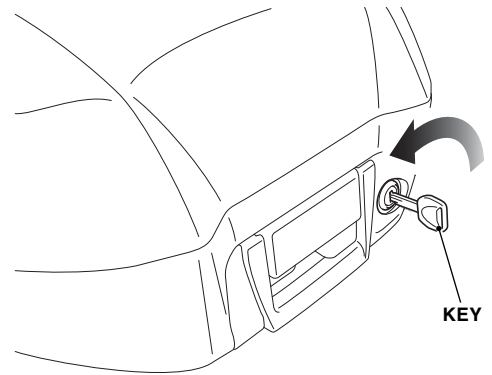
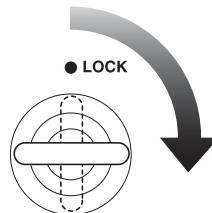

2. Turn the key counter clockwise as shown to lock.

- Confirm that the lid and plate lock are closed securely.

