

PARAMOTORE SPECIFICO - SPECIFIC ENGINE GUARD - PARE-CARTER SPECIFIQUE
 SPEZIFISCHER STURZBÜGEL - DEFENSA DE MOTOR ESPECÍFICA

HONDA CB600F 2007 HORNET

ISTRUZIONI DI MONTAGGIO - MOUNTING INSTRUCTIONS
 INSTRUCCIONES DE MONTAJE - BAUANLEITUNG - INSTRUCCIONES DE MONTAJE

1



PARAMOTORE
 ENGINE GUARD
 PARE-CARTER
 STURZBÜGEL
 DEFENSA DE MOTO

Q.TY n.2 (dx-sx)

2



NIPPLES

Q.TY n.1

3



VITE TCEI M8x30mm
 SCREW M8x30mm
 VIS M8x30mm
 SCHRAUBE M8x30mm
 TORNILLO M8x30mm

Q.TY n.1

4



RONDELLA Ø8mm
 WASHER Ø8mm
 RONDELE Ø8mm
 SCHEIBE Ø8mm
 ARANDELA Ø8mm

Q.TY n.1

5



VITE TE M12x195mm
 Passo 1,25mm, 10.9 nera
 SCREW M10x30mm
 VIS M10x30mm
 SCHRAUBE M10x30mm
 TORNILLO M10x30mm

Q.TY n.1

6



DISTANZIALE Ø18x25mm
 Foro Ø10,5mm, V667
 SPACER
 ENTRETÔISE
 DISTANCIADOR
 DISTANCIADOR

Q.TY n.1

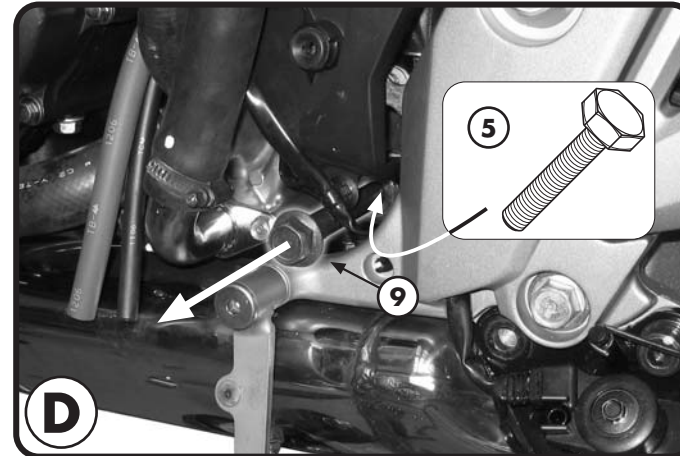
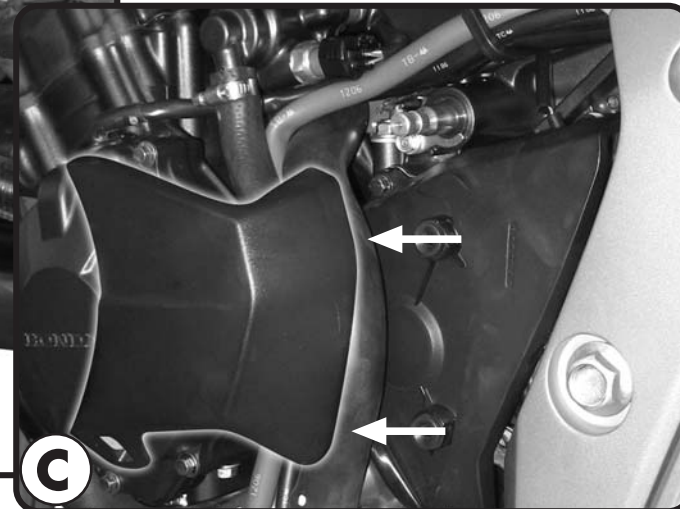
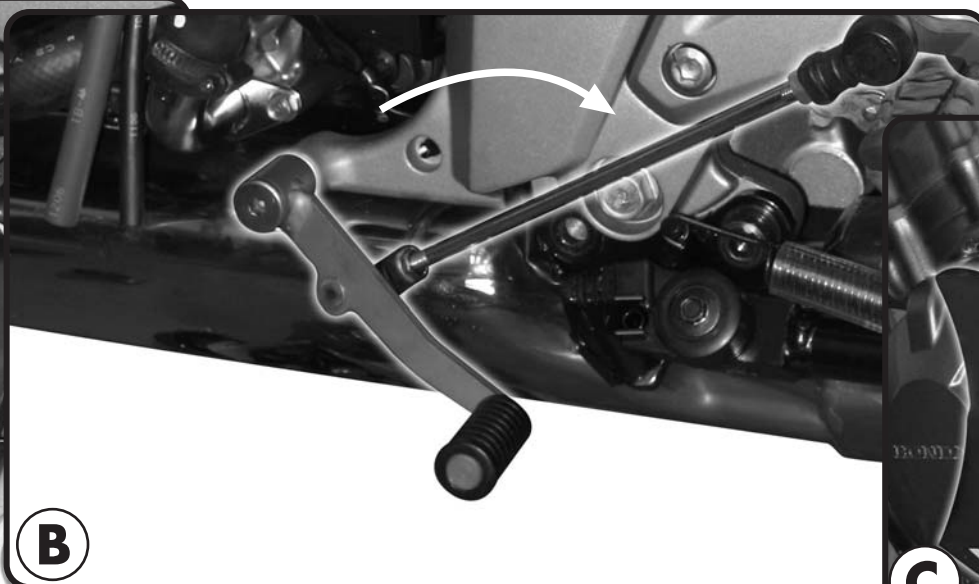
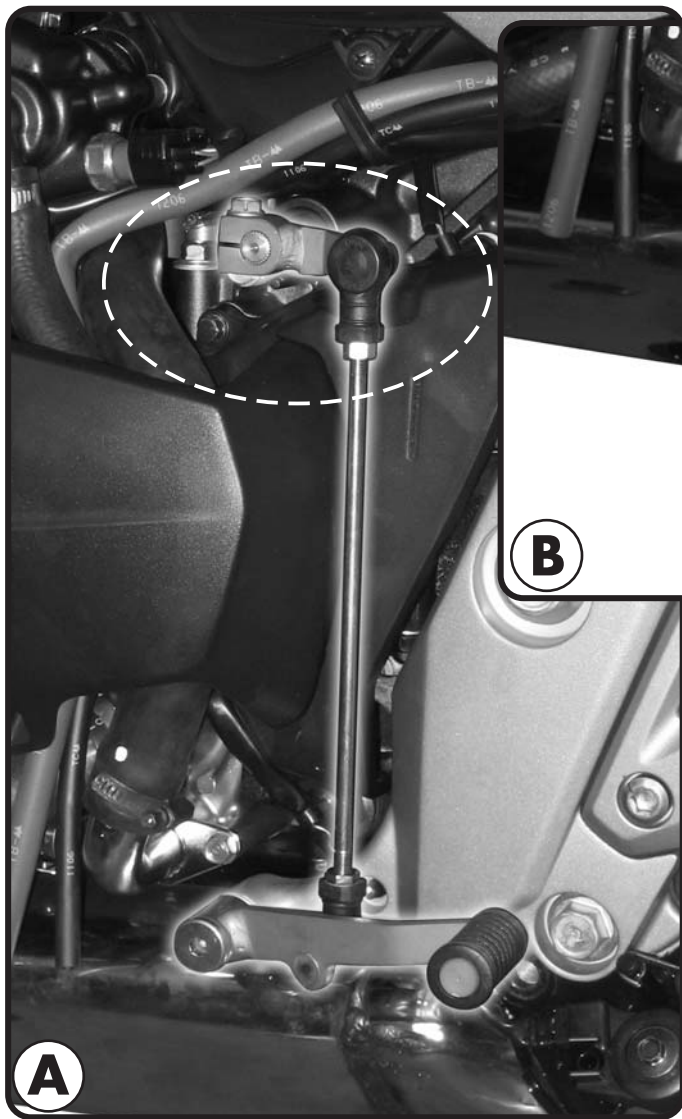

SI RACCOMANDA DI FARE ESEGUIRE IL MONTAGGIO AD UN MECCANICO QUALIFICATO

WE RECOMMEND THAT THE MOUNTING IS CARRIED OUT BY A QUALIFIED MOTORCYCLE MECHANIC

IL EST RECOMMANDE DE FAIRE EXECUTER LE MONTAGE PAR UN MECANICIEN QUALIFIE

WIR EMPFEHLEN, DABß DIE MONTAGE VON EINEM FACHMECHANIKER DURCHGEFÜHRT WIRD

LES RECOMENDAMOS QUE EL MONTAJE DE LA DEFENSA SE REALICE POR UN MECANICO CALIFICADO

TN453-KN453

PARAMOTORE SPECIFICO - SPECIFIC ENGINE GUARD - PARE-CARTER SPECIFIQUE
SPEZIFISCHER STURZBÜGEL - DEFENSA DE MOTOR ESPECIFICA

HONDA CB600F 2007 HORNET

ISTRUZIONI DI MONTAGGIO - MOUNTING INSTRUCTIONS
INSTRUCTIONS DE MONTAGE - BAUANLEITUNG - INSTRUCCIONES DE MONTAJE

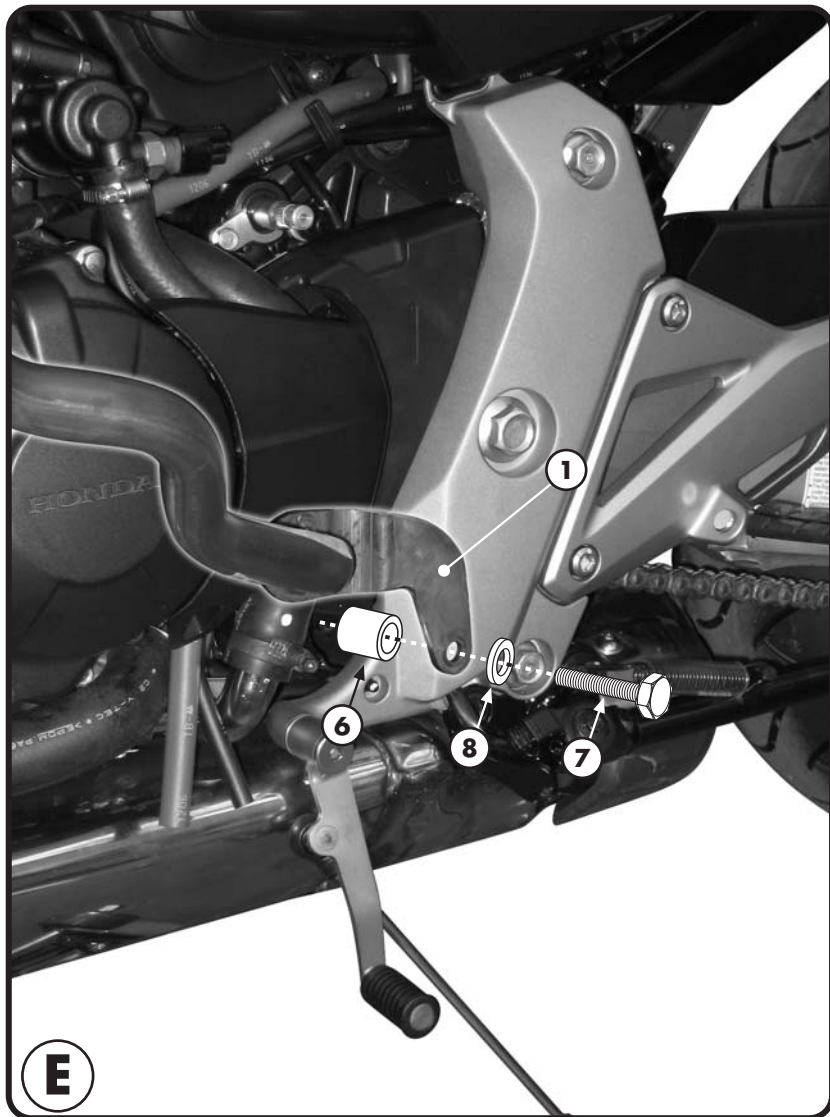

F

10



DISTANZIALE Ø14x20mm
Foro Ø8,5mm, V009
SPACER
ENTRETOISE
DISTANZSTÜCK
DISTANCIADOR

Q.TY n.1

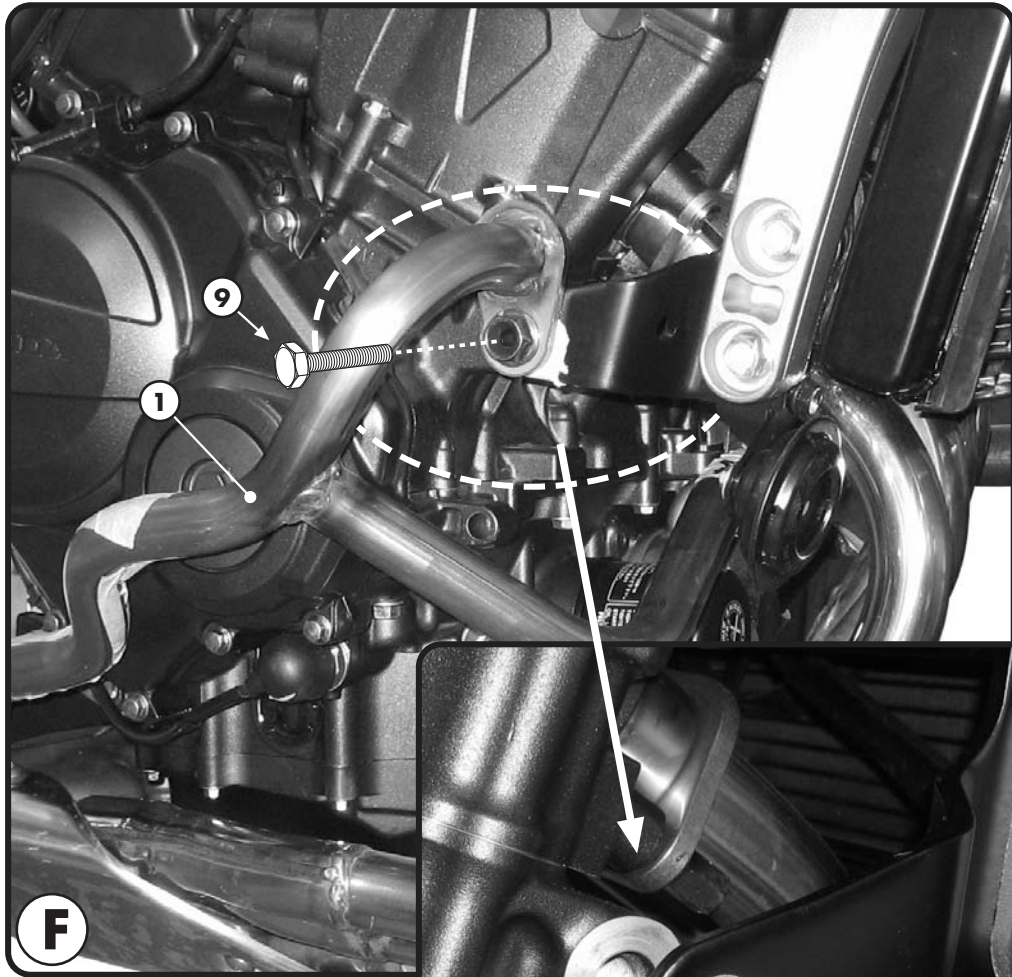

7



VITE TE M10x55mm
Passo 1,25mm, 10.9 nera
SCREW M10x30mm
VIS M10x30mm
SCHRAUBE M10x30mm
TORNILLO M10x30mm

Q.TY n.1

8



RONDELLA Ø10mm
WASHER Ø10mm
RONDELLE Ø10mm
SCHEIBE Ø10mm
ARANDELA Ø10mm

Q.TY n.1

9

COMPONENTI ORIGINALI
ORIGINAL PARTS
PARTIES ORIGINALES
ORIGINAL BAUTEILE
COMPONENTES ORIGINALES

Q.TY n.-



G

PARAMOTORE SPECIFICO - SPECIFIC ENGINE GUARD - PARE-CARTER SPECIFIQUE
 SPEZIFISCHER STURZBÜGEL - DEFENSA DE MOTOR ESPECIFICA

HONDA CB600F 2007 HORNET

ISTRUZIONI DI MONTAGGIO - MOUNTING INSTRUCTIONS
 INSTRUCCIONES DE MONTAJE - BAUANLEITUNG - INSTRUCCIONES DE MONTAJE

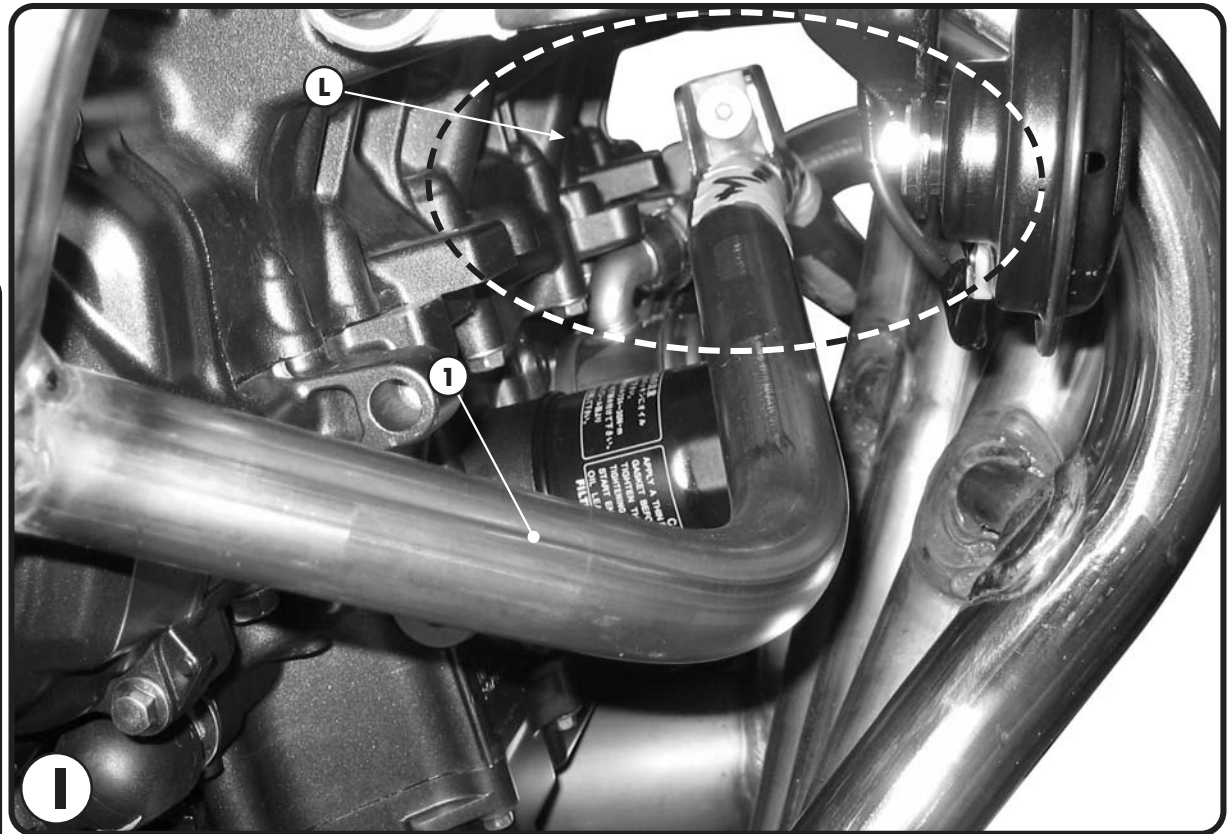

SI RACCOMANDA DI FARE ESEGUIRE IL MONTAGGIO AD UN MECCANICO QUALIFICATO

WE RECOMMEND THAT THE MOUNTING IS CARRIED OUT BY A QUALIFIED MOTORCYCLE MECHANIC

IL EST RECOMMANDE DE FAIRE EXECUTER LE MONTAGE PAR UN MECANICIEN QUALIFIE

WIR EMPFEHLEN, DAß DIE MONTAGE VON EINEM FACHMECHANIKER DURCHFÜHRT WIRD

LES RECOMENDAMOS QUE EL MONTAJE DE LA DEFENSA SE REALICE POR UN MECANICO CALIFICADO

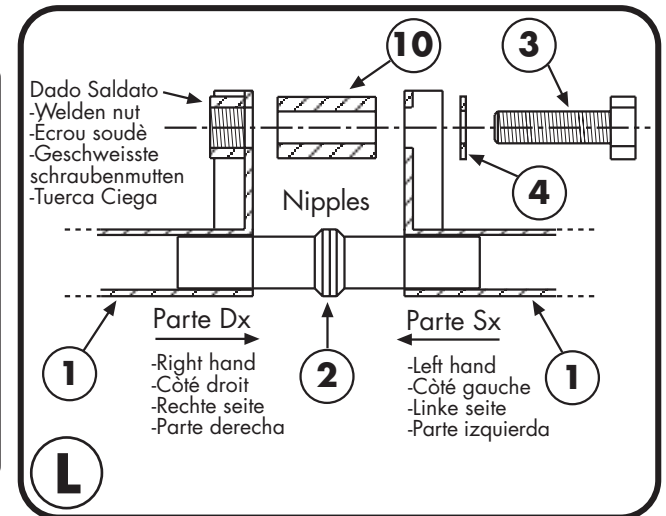

PARAMOTORE SPECIFICO - SPECIFIC ENGINE GUARD - PARE-CARTER SPECIFIQUE
SPEZIFISCHER STURZBÜGEL - DEFENSA DE MOTOR ESPECIFICA

HONDA CB600F 2007 HORNET

ISTRUZIONI DI MONTAGGIO - MOUNTING INSTRUCTIONS
INSTRUCTIONS DE MONTAGE - BAUANLEITUNG - INSTRUCCIONES DE MONTAJE

I ISTRUZIONI DI MONTAGGIO

1. PRIMA DI EFFETTUARE IL MONTAGGIO DEL PARAMOTORE BISOGNA SOSTITUIRE IL PERNO ORIGINALE EVIDENZIATO IN FOTOGRAFIA D CON IL PARTICOLARE N°5; PER FACILITARE L'OPERAZIONE BISOGNA SMONTARE LA LEVA DEL CAMBIO (FOTOGRAFIA A E B) ED IL CARTER DI PLASTICA EVIDENZIATO IN FOTOGRAFIA C;
2. UNA VOLTA INSTALLATO IL PARTICOLARE 5 RIMONTARE IL CARTER DI PLASTICA E LA LEVA DEL CAMBIO COME DA LORO POSIZIONE ORIGINALE;
3. MONTARE QUINDI IL PARAMOTORE SEGUENDO LE INDICAZIONI DI FOTOGRAFIA E, F, H ED I; FARE PARTICOLARE ATTENZIONE AL DISTANZIALE ORIGINALE INTERESSATO NEL MONTAGGIO DI FOTOGRAFIA F E NEL DETTAGLIO IN FOTOGRAFIA G: FATE ATTENZIONE CHE RIMANGA NELLA SUA POSIZIONE DI ORIGINE MENTRE VI APPRESTATE A MONTARE IL VOSTRO NUOVO PARAMOTORE;
4. ULTIMARE IL MONTAGGIO CONTROLLANDO CHE TUTTE LE VITI SIANO SERRATE BENE.

GB MOUNTING INSTRUCTIONS

1. BEFORE MOUNTING THE ENGINE GUARD YOU NEED TO CHANGE THE ORIGINAL PIN SHOWN IN PICTURE D WITH THE PART N° 5; IN ORDER TO MAKE THIS OPERATION EASIER IT IS NECESSARY TO REMOVE THE GEAR LEVER (PICTURES A AND B) AND THE PLASTIC COVER SHOWN IN PICTURE C;
2. ONCE YOU HAVE INSTALLED THE PART N° 5 REMOUNT THE PLASTIC COVER AND THE GEAR LEVER IN THEIR ORIGINAL POSITION;
3. NOW MOUNT THE ENGINE GUARD FOLLOWING THE INDICATIONS OF PICTURES E, F, H AND I; PAY PARTICULAR ATTENTION TO THE ORIGINAL SPACER INVOLVED IN THE MOUNTING OF PICTURE F AND TO THE DETAILS OF PICTURE G, CHECK THAT THIS REMAINS IN ITS ORIGINAL POSITION WHILE MOUNTING THE ENGINE GUARD;
4. LASTLY CHECK THAT ALL SCREWS HAVE BEEN TIGHTENED.

F INSTRUCTIONS DE MONTAGE

1. AVANT D'EXECUTER LE MONTAGE DES PARE CARTERS IL FAUT REMPLACER L'AXE D'ORIGINE MARQUE EN PHOTO D PAR LA PIECE N°5; POUR FACILITER L'OPERATION IL FAUT DEMONTER LE LEVIER DE CHANGEMENT DE VITESSES (PHOTOS A ET B) ET LE CARTER EN PLASTIQUE MARQUE EN PHOTO C;
2. UNE FOIS LA PIECE N°5 INSTALLEE, REMONTER LE CARTER EN PLASTIQUE ET LE LEVIER DE CHANGEMENT DE VITESSES DANS LEUR POSITION ORIGINALE;
3. ENSUITE, MONTER LES PARE CARTERS EN SUIVANT LES INSTRUCTIONS DES PHOTOS E, F, H ET I; FAIRE PARTICULIEREMENT ATTENTION AUX ENTRETOISES D'ORIGINE CONCERNEES PAR LE MONTAGE EN PHOTO F ET G; FAIRE ATTENTION A CE QU'ELLES RESTENT DANS LEUR POSITION D'ORIGINE PENDANT LE MONTAGE DES NOUVEAUX PARE CARTERS;
4. TERMINER LE MONTAGE EN CONTROLANT LE BON SERRAGE DE TOUTES LES VIS.

D BAUANLEITUNG

1. BEVOR SIE DIE MONTAGE DES STURZBÜGELS DURCHFÜHREN, IST ES NOTWENDIG, DEN ORIGINAL ZAPFEN VOM BILD D MIT DEM TEIL NR. 5 AUSZUWECHSELN; UM DIESES VORGEHEN ZU ERLEICHTERN, SOLLEN SIE DEN SCHALTHEBEL (BILDER A UND B) UND DEN KUNSTSTOFFKASTEN VOM BILD C ABMONTIEREN;
2. WENN SIE DAS TEIL NR. 5 MONTIERT HABEN, MONTIEREN SIE DEN KUNSTSTOFFKASTEN UND DEN SCHALTHEBEL WIEDER AN IHRE ORIGINALSTELLE;
3. NUN MONTIEREN SIE DEN STURZBÜGEL MIT DEN HINWEISEN VON BILDER E, F, H UND I; PASSEN SIE AUF DAS ORIGINAL DISTANZSTÜCK VOM BILD F UND AUF DAS DETAIL VOM BILD G; DASS ES AN DER ORIGINALSTELLE BLEIBT BEI DER MONTAGE DES STURZBÜGELS;
4. ZULETZT ÜBERPRÜFEN SIE, DASS ALLE SCHRAUBEN FESTGEZOGEN WURDEN.

ES

INSTRUCCIONES DE MONTAJE

1. ANTES QUE EFECTUAR EL MONTAJE LA DEFENSA ES NECESARIO SUSTITUIR EL FULCRO PERNO ORIGINAL MARCADO EN FOTOGRAFÍA D CON LA REFERENCIA N° 5. PARA FACILITAR LA OPERACIÓN ES NECESARIO DESMONTAR LA PALANCA DEL CAMBIO (FOTOGRAFÍAS A Y B) Y EL CARTER DE PLÁSTICO INDICADO EN LA FOTOGRAFÍA C;
2. UNA VEZ INSTALADA LA REFERENCIA 5 MONTAR OTRA VEZ EL CARTER DE PLÁSTICO Y LA PALANCA DEL CAMBIO EN SU POSICIÓN ORIGINAL;
3. MONTAR LA DEFENSA SIGUIENDO LAS INDICACIONES INDICADAS EN LAS FOTOGRAFÍAS E, F, H Y I. PRESTAR ATENCIÓN AL SEPARADOR ORIGINAL INDICADO EN LA FOTOGRAFÍA F Y EN EL DETALLE DE LA FOTOGRAFÍA G. TENER CUIDADO QUE SE QUEDE EN LA POSICIÓN ORIGINAL MIENTRAS MONTAIS LA NUEVO DEFENSA.
4. TERMINAR EL MONTAJE VIGILANDO QUE LOS TORNILLOS ESTÈN BIEN AJUSTADOS

