



INSTALLATION INSTRUCTIONS

Accessory
WINDSCREEN AIR DEFLECTOR
P/N 08R80-MGE-100

Application
VFR1200F

Publications No.
MII 13068
 Issue Date
February 2010

Honda Dealer: Please give a copy of these instructions to your customer.

PARTS LIST

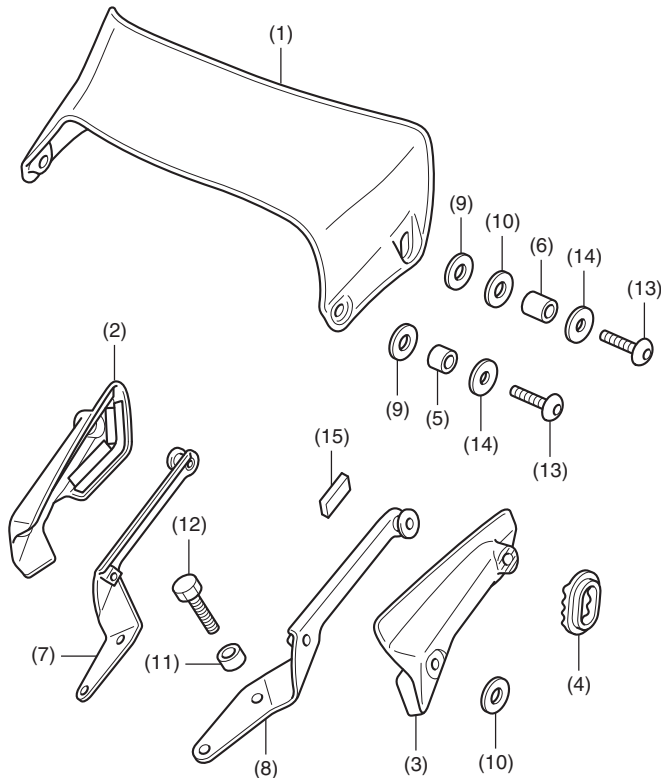

No.	Description	Qty
(1)	Air deflector	1
(2)	Right deflector cover	1
(3)	Left deflector cover	1
(4)	Adjust plate	2
(5)	Collar (medium)	2
(6)	Collar (long)	2
(7)	Right deflector bracket	1
(8)	Left deflector bracket	1
(9)	Plastic washer	4
(10)	Rubber washer	4
(11)	Collar (short)	2
(12)	6 mm hex bolt	2
(13)	6 mm socket bolt	4
(14)	Washer	4
(15)	Cushion tape	2

TOOLS AND SUPPLIES REQUIRED

- Socket (10 mm)
- Ratchet
- Hex wrench (5 mm)
- Isopropyl alcohol
- Shop towel
- Torque wrench

TORQUE CHART

Tighten all screws, bolts, and nuts to their specified torque values. Refer to the Service Manual for the torque values of the removed parts.

Item	N-m	kgf-m	lbf-ft
6 mm socket bolt	10	1.0	7
6 mm hex bolt	10	1.0	7

USE AND CARE INFORMATION

- Replace this accessory with a new one if it is damaged or discolored excessively.
- When this accessory becomes dirty, rinse it thoroughly with cool water to remove loose dirt, then wipe with a clean cloth or sponge. Do not use a brush to clean this accessory as it may scratch the surface.
- Never use petroleum solvents such as gasoline, thinner, or benzine to clean this accessory. Also do not use acid or alkaline cleaners. Wipe up spilled brake or battery fluid at once as they may damage the plastic surface.
- Check the accessory mounts frequently and retighten if necessary.
- When folding the mirrors downward, fold them towards the front. When folding them down towards the rear they will interfere with the windscreen air deflector.

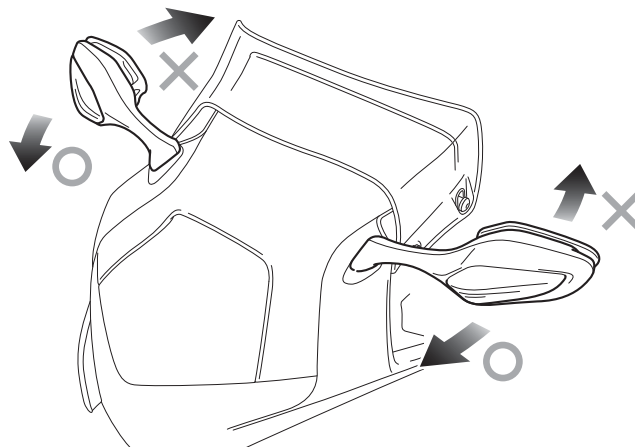

INSTALLATION

NOTE:

- Heat the bonding surfaces with a hair dryer if the ambient air temperature is below 70°F (21°C).
- The adhesive reaches full strength in 72 hours. Wait at least 24 hours before riding your motorcycle.

1. Tilt the left mirror forward as shown.

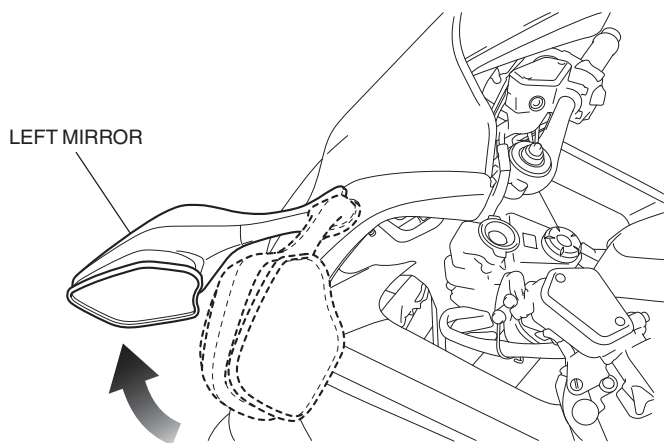

2. Remove the nuts as shown.

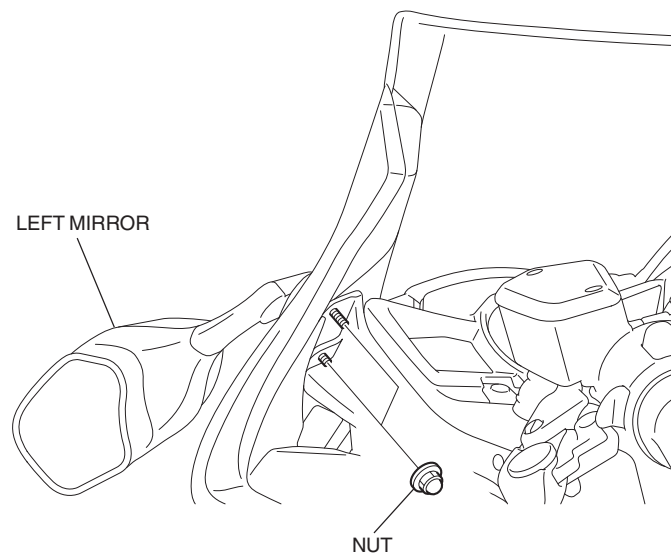

3. Replace the upper bolt with the 6 mm hex bolt as shown.

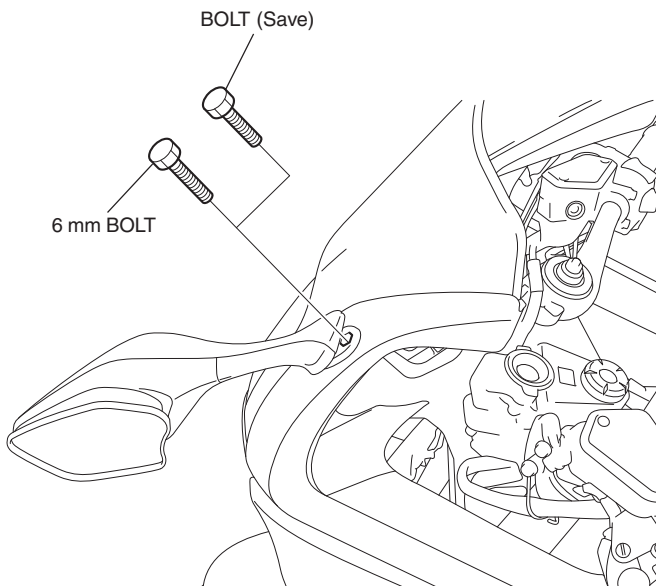

4. Clean the surface of the area shown using isopropyl alcohol.

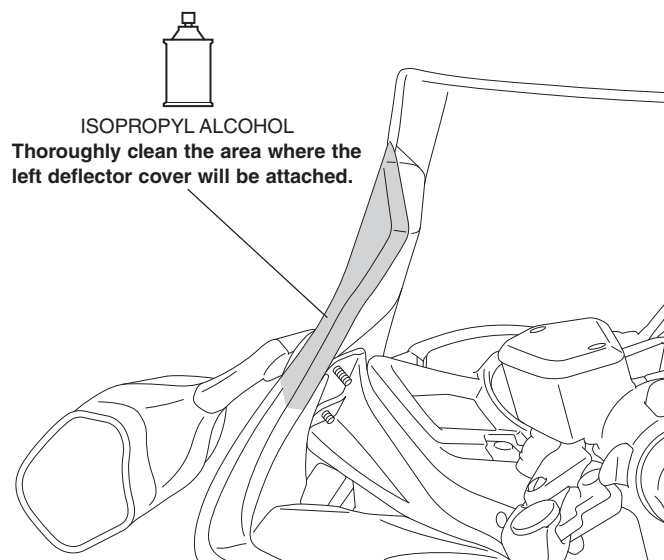

5. Attach the cushion tape in the position shown.

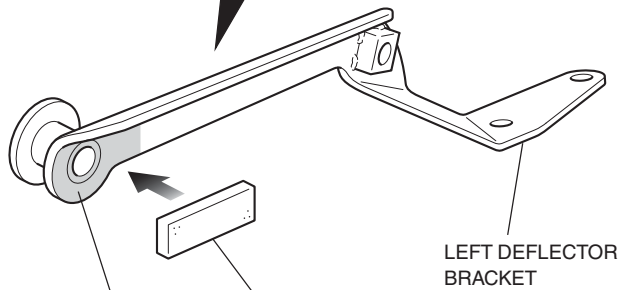
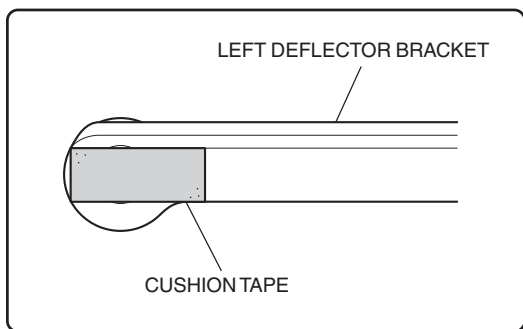

CUSHION TAPE
Remove the adhesive backing before attaching.



ISOPROPYL ALCOHOL
Thoroughly clean the area where the left deflector bracket will be attached.

6. Loosely install the left deflector bracket as shown.

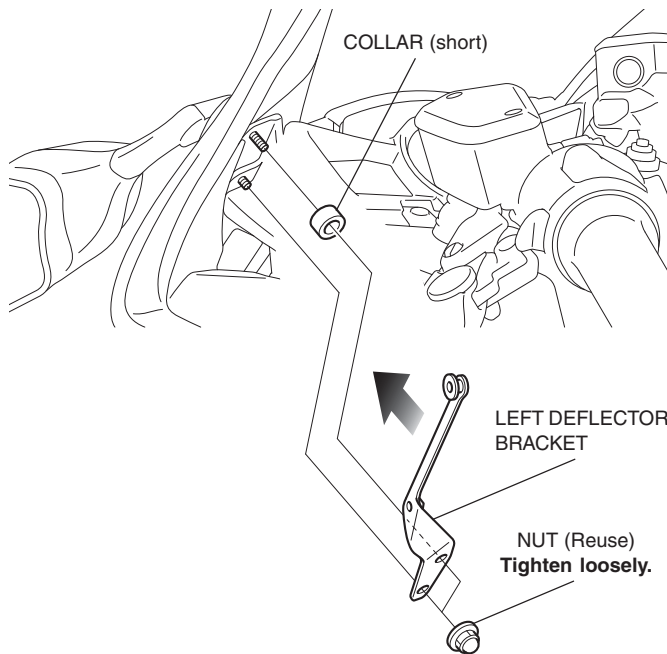

7. Attach the left deflector cover as shown.

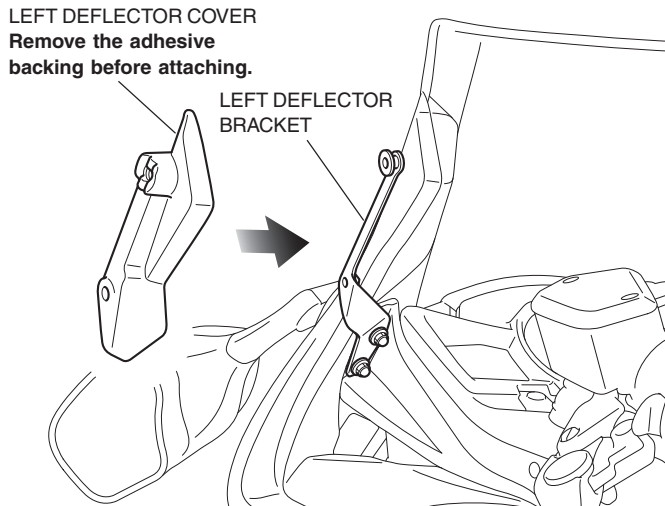

8. Tighten the nuts of the left mirror as shown.

- Tighten the nut while pressing down on the left deflector cover.

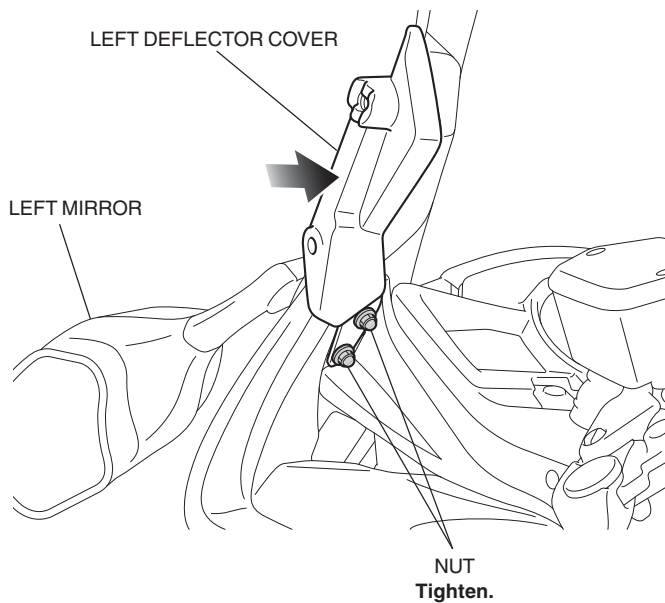

9. Repeat on the right side.

10. Assemble the 6 mm socket bolts as shown.

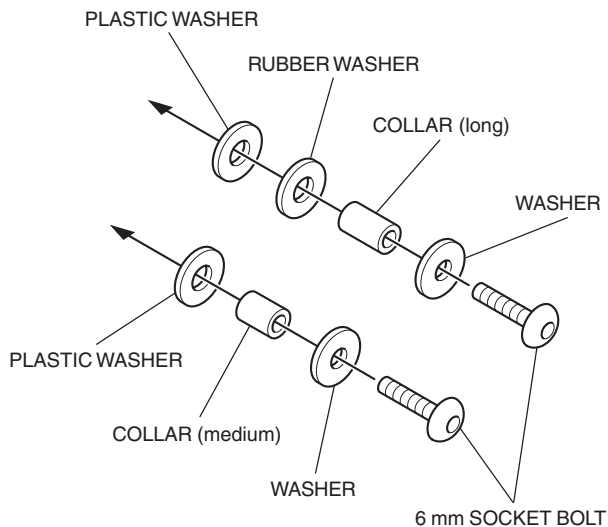

11. Install the windscreen deflector as shown.

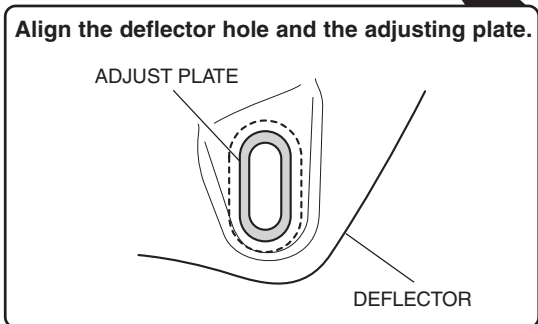
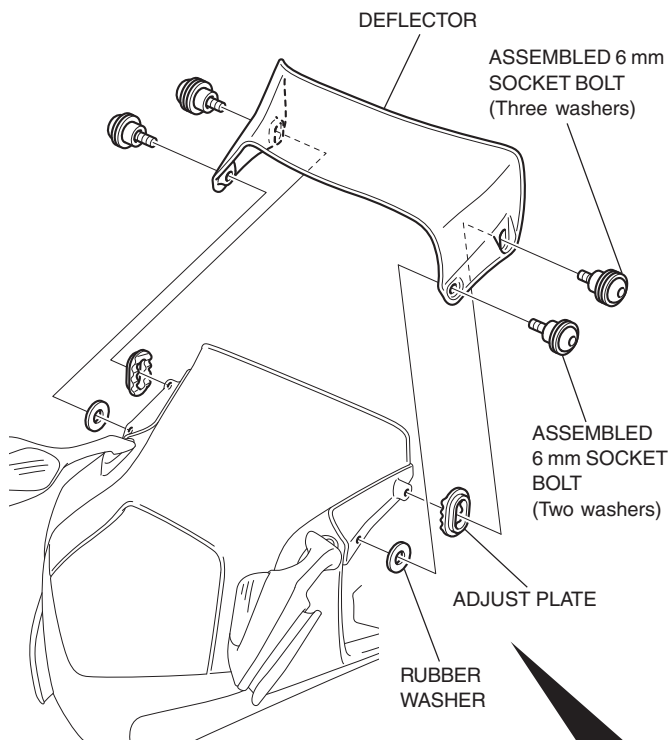

12. Return the left and the right mirrors to their original positions.

Adjustment method

- The deflector height can be adjusted in three positions as desired.

1. Loosen the left and the right screw as shown.

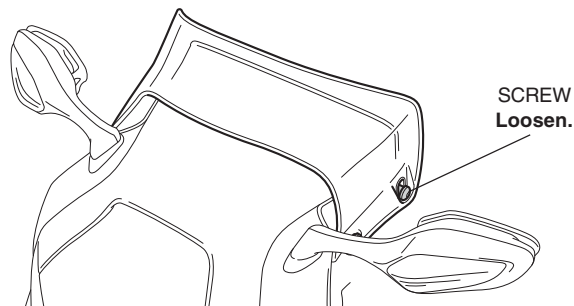

2. Hold both ends of the deflector and raise or lower it as shown.

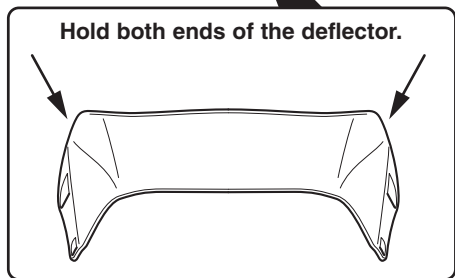
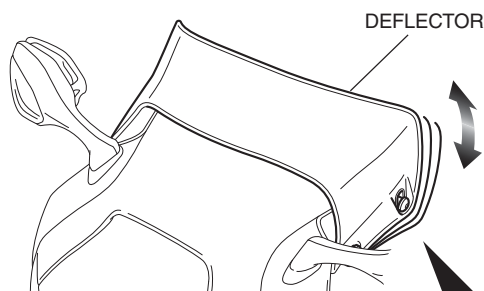

3. Tighten the left and the right screw as shown.

