



INSTALLATION INSTRUCTIONS

Accessory
19" ALUMINUM WHEEL

Application
2021 CR-V

Publications No.
VERSION 1
Issue Date
OCT 2020

PARTS LIST

Aluminum Wheel Kit
P/N 08W19-TLA-100A
P/N 08W19-TLA-100B

*: The part defers depending on the kits.

Aluminum wheel
(The illustration may differ from the actual wheel.)



Wheel center cap
(The illustration may differ from the actual center cap.)



Valve



TPMS Information
(This is for models not equipped with standard 19" wheels. Make sure your customer receives this information.)

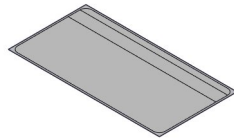

Tire pressure information label A
(May not be used)

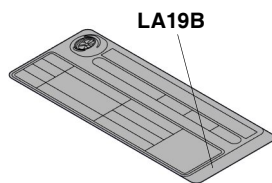

Tire pressure information label B
(May not be used)

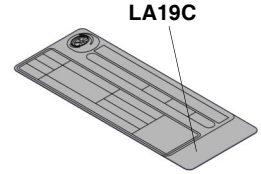

*: Wheel cleaning Information
(Make sure customer receives this information.)
(P/N 08W19-TLA-100B)

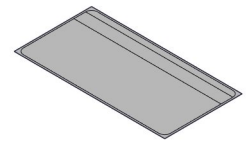

Supplemental information
(This is for models not equipped with standard 19" wheels. Make sure your customer receives this information.)

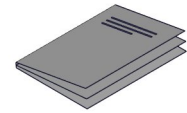

TOOLS AND SUPPLIES REQUIRED

- Isopropyl alcohol
- Shop towel
- i-HDS
- Ratchet
- 19 mm Socket
- Torque wrench

SPECIFICATIONS

Rim size	19 x 7 1/2J (inset 45)	
Tire size	235/55R19 101H	
Bolt hole PCD	114.3 (5 holes)	
Tire pressure	Front	33 psi (230 kPa)
	Rear	33 psi (230 kPa)

INSTALLATION

Customer Information: The information in this installation instruction is intended for use only by skilled technicians who have the proper tools, equipment, and training to correctly and safely add equipment to your vehicle. These procedures should not be attempted by “do-it-yourselfers.”

NOTE:

- The illustrations of the aluminum wheels are shown for reference purposes only.
- Install the correct size tire.
- Use a tire changer to install and remove the tires as described in the operation manual furnished with the tire changer. Do not use a tire lever to install and remove the tires as it may cause damage to the tire and aluminum wheel.
- The wheel nut torque is 80 lb-ft (108 N·m).
- This kit should be installed only if the ambient air temperature is 60°F (15°C) or above.
- To allow the adhesive to cure, do not wash the vehicle for 24 hours. Make sure the customer is aware of this.

Models equipped with standard 19" wheels:

Discard the TPMS information, tire pressure information label, and supplemental information in this kit.

Do steps 1-17 for models not equipped with standard 19" wheels.

1. Open the driver's door. Using isopropyl alcohol on a shop towel, thoroughly clean the area where the accessory tire pressure information label will attach. Remove the adhesive backing from the accessory tire pressure information label, and attach the accessory tire pressure information label over the standard tire pressure information label as shown. NOTE: Confirm the spare tire size, and appropriate label.

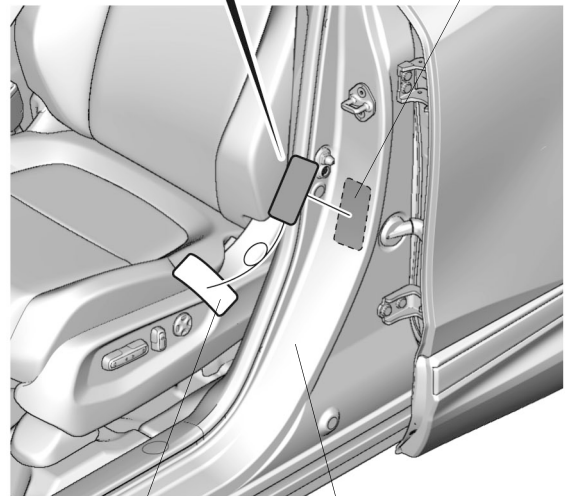
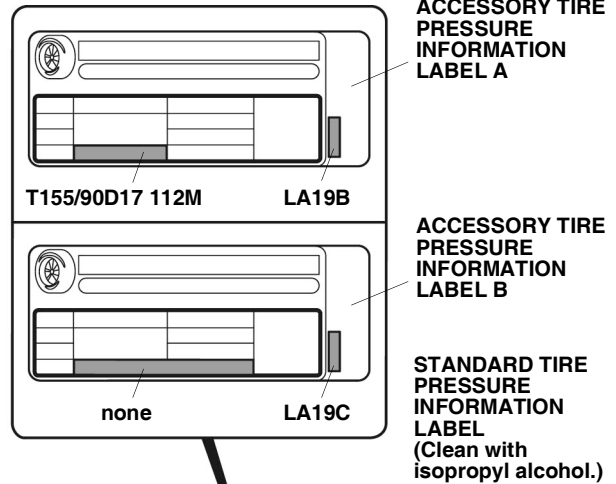

QHD2404AX

2. Attach the Supplemental Information page included in this kit into the Owner's Guide as described on the Important Information to Dealer page.

Inch-up Tire Pressure Programming

NOTE: Make sure you are using the latest i-HDS version as described on SIS.

3. Connect the i-HDS to the data link connector, then turn the ignition to ON.
4. Start the Diagnostic System, select **Connect to the Vehicle**.
5. Select **System Selection Menu**.
6. Select **ABS/VSA**, and click the check button.
7. Select **TPMS (VSA) threshold**, and click the check button.
8. Select **YES**.
9. Select **YES**.
10. Select **19 inch**, and click the check button.
11. Select **Mud and snow**, and click the check button.
12. When you see this message: **Turn the ignition switch off**. Turn the ignition to OFF.
13. When you see this message: **Turn the ignition switch on**. Turn the ignition to ON.
14. Click the check button.
15. Disconnect the i-HDS from the data link connector.
16. Do the TPMS calibration according to the instructions in the service information (TPMS Calibration).
17. After finishing the work, write tire size, tire pressure, i-HDS version, dealer name, technician's signature, and date in Service History Page for Honda Accessory Alloy Wheels page included in this kit.
 - Be sure to explain the contents of the Supplemental Information when delivering the vehicle to your customer.

Deflation Warning System Threshold Rewriting

- If the standard 18-inch wheels are to be installed back on the vehicle, you must change the threshold value with the i-HDS; refer to steps 3 to 16.
- For step 10, select the 18-inch.

NOTE: If 18-inch is displayed on the current wheel size settings, go to step 15.

- Attach the standard tire pressure information label over the old label in the driver's door jamb.
- After finishing the work, write tire size, tire pressure, i-HDS version, dealer name, technician's signature, and date in Service History Page for Honda Accessory Alloy Wheels page.